

# ProxPass® II Active Tag

125 kHz Proximity

Long Range Proximity for Vehicle Access Control • 1351

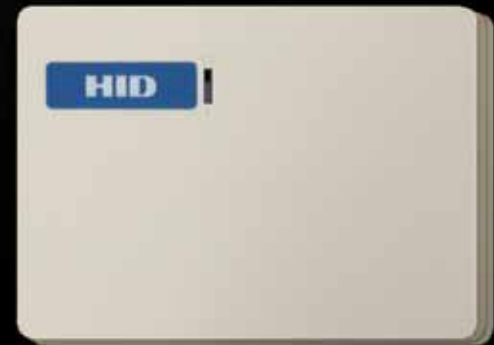

## **ACCESS** reliability.

### Application

The ProxPass® II is an active tag specifically designed for vehicle access control. Providing convenient access control for parking and fleet management applications, ProxPass II is an ideal augmentation to an existing or new HID proximity installation. The ProxPass II can be encoded with any HID format and numbering system used by HID proximity cards, including the Corporate 1000 format.

### Features

- ▶ Access door permits convenient battery replacement.
- ▶ Provides up to six foot read range.
- ▶ Velcro backing attaches easily to interior of vehicle windshield.
- ▶ Attractive, durable sealed case.
- ▶ Compatible with MaxiProx® reader and all HID card formats.
- ▶ Two to five year battery life, depending on usage.
- ▶ Competitively priced as compared to VHF vehicle tags.

- Description** RF-programmable, customer specified ID numbers
- Options** External numbering
- Easily Administered** A cross-reference list correlating the external card number and the programmed ID number provides easy system administration.
- Security** Offers over 137 billion unique codes.
- Long Life** Dual battery design and low current draw allows two to five years with typical usage. (Replaceable battery)
- Durability** Rugged, UV-resistant, sonic-welded polycarbonate case is also weather resistant
- Warranty** One year warranty against defects in materials and workmanship (see complete sales policy for details).

**\*Read Range using MaxiProx® reader**  
 Up to 6' (1.8 m)  
 \*Depending on local installation conditions.

**Mounting Location**  
 Interior windshield, driver's side, upper or lower corner

**Note:** Ideal mounting location is on interior windshield glass. Mounting on metal will degrade performance.

**Dimensions**  
 3.625" x 2.65" x 0.30"  
 (9.25cm x 6.75cm x .76cm)

**Operating Temperature**  
 -22° to 185° F (-30° to +85° C)

**Battery**  
 Two Panasonic lithium (Model BR2330)

**Environmental**  
 5 – 95% RH, non-condensing  
 (Not for marine usage)

**Certifications**  
 FCC Certification, Canada Certification, CE Mark (Europe), New Zealand, Australia c-Tick, Taiwan

(Please see "How to Order Guide" for a description of the options and associated part numbers.)

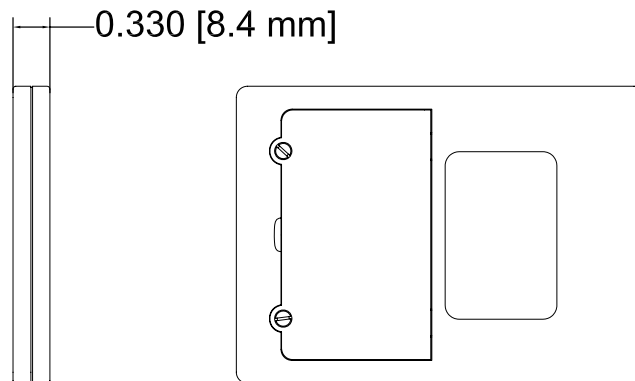
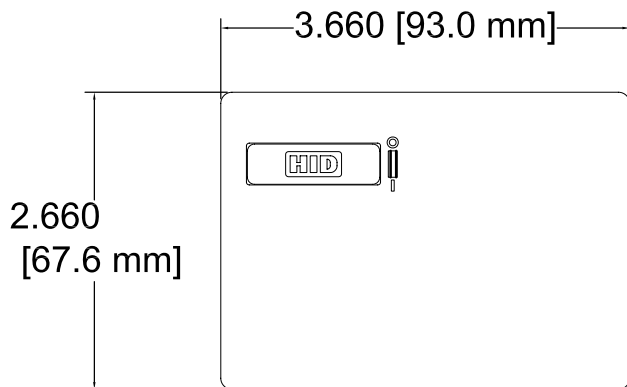

© 2009 HID Global. All rights reserved. HID, and the HID logo are trademarks or registered trademarks of HID Global in the U.S. and/or other countries. All other trademarks, service marks, and product or service names are trademarks or registered trademarks of their respective owners. Rev. 07/2009

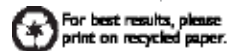

MKT-PROXPASSII-DS-EN



**ACCESS** experience.

[hidglobal.com](http://hidglobal.com)

**HID Global Offices:**

**Corporate North America**  
 15370 Barranca Pkwy  
 Irvine, CA 92618  
 U.S.A.  
 Phone: (800) 237-7769  
 Phone: (949) 732-2000  
 Fax: (949) 732-2360

**Asia Pacific**  
 19/F 625 King's Road  
 North Point  
 Island East  
 Hong Kong  
 Phone: +852 3160-9800  
 Fax: +852 3160-4809

**Latin America**  
 Circunvalacion Ote. #201 B  
 Despacho 2  
 Col. Jardines del Moral  
 Leon 37160, Gto.  
 Mexico  
 Phone: +52 477 779 1492  
 Fax: +52 477 779 1493

**Europe, Middle East & Africa**  
 Haverhill Business Park  
 Phoenix Road  
 Haverhill  
 Suffolk  
 CB9 7AE  
 England  
 Phone: +44 (0) 1440 714 850  
 Fax: +44 (0) 1440 714 840



## About BarcodesInc

### Who We Are

BarcodesInc is North America's leading provider of... [The following text is heavily garbled and appears to be a placeholder or corrupted content.]

### We Owe Our Success To You

Our success is due to the support of our customers... [The following text is heavily garbled and appears to be a placeholder or corrupted content.]

## Why Choose BarcodesInc?

### Dedicated Account A UbU Yf

Our Account Managers will not compromise when it comes to providing you top-notch service. Your Account Manager is the primary point of contact for your business and makes it a priority to get to know you, your company and all your needs.

### Highly-Trained Technical Support

Our technical staff has the broadest knowledge and every significant certification in the industry. One of our friendly experts is always available to suggest products and solutions for any situation.

### Incredible Value

Our purchasing power means big savings for you. Whatever your project, our team will work hard to deliver a solution that fits your budget.

### Largest Inventory in the Industry and Same-Day Shipping

Whatever your barcoding, mobile computing, or printing needs, we will fill your order and ship it the same day.

### Premier Access to Top Manufacturers

BarcodesInc maintains strong strategic partnerships with the leading manufacturers in barcoding, mobile computing, printing and RFID.

### Responsive Customer Service

Every phone call and email is responded to promptly, completely and accurately by our customer service team.

### Easy Returns

Damaged, defective or incorrectly ordered goods may be returned without hassle.

## BRANDS



AND MORE