



QPI - 5425 NEW

- ❖ 540 TV Lines
- ❖ 25m IR
- ❖ 6mm Fixed Lens
- ❖ IP66

540TVL, 25m IR Camera



❖ FEATURES

- 1/3" Sony Interline Transfer CCD
- 540TVL Hi-Resolution
- Low Power Consumption(80mA/Color,330mA/LED ON)
- NO Focus Shift in Night Time (when LED Turn ON)
- CDS Auto Switching IR-LED Control
- 25m Viewable Length at Night
- 6mm Fixed Lens Built-in
- DC 12V operation
- Waterproof (IP66)

❖ DIMENSIONS

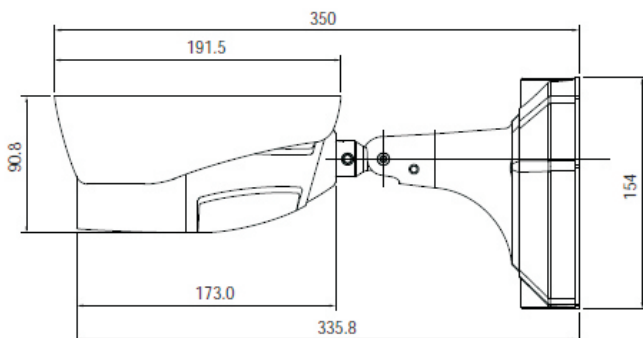

Unit : mm

❖ SPECIFICATIONS

MODEL	QPI-5425
Image Sensor	1/3" Sony Interline Transfer CCD
Effective Pixels	752H x 582V (440K pixels)
Scanning System	625 Lines 2:1 Interlace
Scanning Frequency	15.625KHz (H), 50Hz (V)
Resolution	540TV Lines
Shutter Speed	1/50~1/100,000sec
S/N Ratio	More than 48dB (AGC Off)
Sync. System	Internal
Min.Illumination	0 Lux with IR-LED (30Nos)
Video Output	CVBS :1.0Vp-p (75 ohm Load)
Lens	6mm Fixed Lens (55°)
Power Supply	DC12V ±10%
Power Consumption	80mA (DC12V) / 330mA (IR LED ON)
Operating Temp.	-10°C ~ +50°C
Operating Humidity	90%RH max.



Day

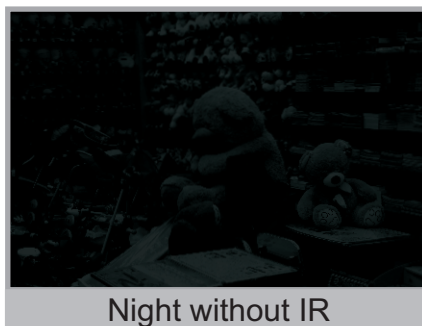

Night without IR

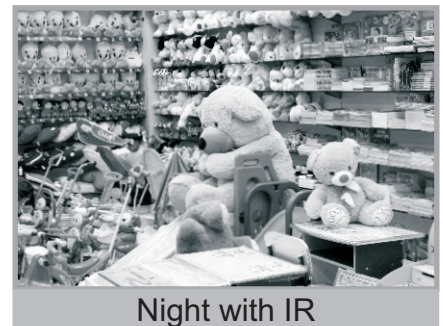

Night with IR