



QPI - 6055 NEW

- 600TV Lines
- 55m IR
- 8mm Fixed Lens
- IP66

600TVL, 55m IR Camera



FEATURES

- 1/3" Sony Interline Transfer CCD
- 600TVL Hi-Resolution
- IR Intelligence
- DNR (Digital Noise Reduction)
- DPC (Dead Pixel Compensation)
- Low Power Consumption(80mA/Color,330mA/LED ON)
- NO Focus Shift in Night Time (when LED Turn ON)
- CDS Auto Switching IR-LED Control
- 55m Viewable Length at Night
- 8mm Fixed Lens Built-in
- DC 12V operation
- Waterproof (IP66)

DIMENSIONS

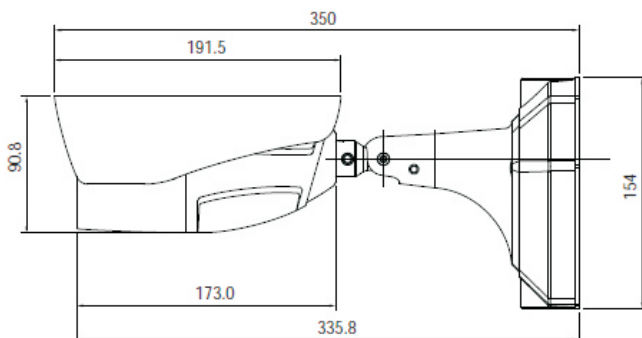

Unit : mm

SPECIFICATIONS

MODEL	QPI-6055
Image Sensor	1/3" Sony Interline Transfer CCD
Effective Pixels	752H x 582V (440K pixels)
Scanning System	625 Lines 2:1 Interlace
Scanning Frequency	15.625KHz (H), 50Hz (V)
Resolution	600TV Lines (color), 700TV Lines (B&W)
Shutter Speed	1/50~1/100,000sec
S/N Ratio	More than 48dB (AGC Off)
Sync. System	Internal
Min.Illumination	0 Lux with IR-LED (66pcs)
Video Output	CVBS :1.0Vp-p (75 ohm Load)
Lens	8 mm Fixed Lens (68°)
Power Supply	DC12V ±10%
Power Consumption	80mA (DC12V) / 330mA (IR LED ON)
Operating Temp.	-10°C ~ +50°C
Operating Humidity	90%RH max.