



# QPI - 6325i NEW

- 630TV Lines
- 25m IR
- 6mm Fixed Lens
- IP66

## 630TVL, 25m IR Camera **IMPROVED**



### FEATURES

- 1/3" Sony Interline Transfer CCD
- 630TVL Hi-Resolution
- Supports IR Intelligence
- 3D-DNR (Digital Noise Reduction)
- Sens-up with DSS (Digital Slow Shutter)
- DWDR (Digital Wide Dynamic Range)
- 24Nos of IR LED (Viewable length - 25m)
- Low Power Consumption(80mA/Color,350mA/LED ON)
- 6mm Fixed Lens Built-in
- DC 12V operation
- IP-66 Water-proof

### DIMENSIONS

Unit : mm

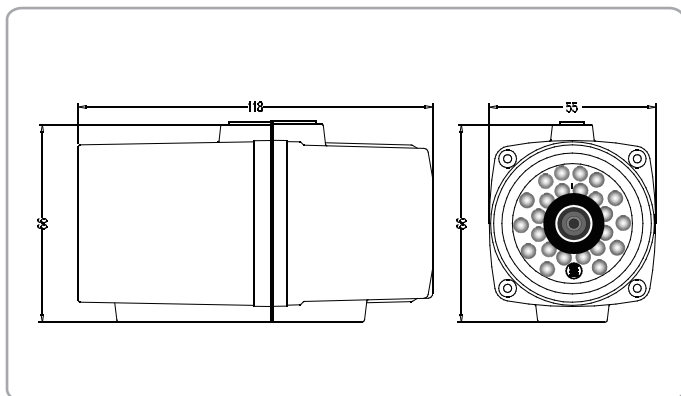

### IP66 (Ingress Protection Rating)

The heavy-duty waterproof aluminum die-cast housing completely protects the mechanism from dust and high-pressured water allowing the camera to be used in even the most extreme environments.

### SPECIFICATIONS

MODEL	QPI-6325i
Image Sensor	1/3" Sony Interline Transfer CCD
Effective Pixels	752H x 582V (440K pixels)
Scanning System	625 Lines 2:1 Interlace
Scanning Frequency	15.625KHz (H), 50Hz (V)
Resolution	630TV Lines (color), 700TV Lines (B&W)
Shutter Speed	1/50~1/100,000sec
S/N Ratio	More than 48dB (AGC Off)
Sync. System	Internal
Min.Illumination	0 Lux with IR-LED (30pcs)
Video Output	CVBS :1.0Vp-p (75 ohm Load)
Lens	6 mm Fixed Lens (55°)
Power Supply	DC12V ±10%
Power Consumption	80mA (DC12V) / 330mA (IR LED ON)
Operating Temp.	-10°C ~ +50°C
Operating Humidity	90%RH max.