

BEAM355 and BEAM355S

Single-Ended, Reflected-Type Addressable Beam Smoke Detectors



Addressable Devices

GENERAL

The FireLite BEAM355 and BEAM355S are intelligent, addressable reflected beam smoke detectors for protecting open areas with high and sloping ceilings, and wide-open areas, where spot-type smoke detectors are difficult to install and maintain. Ideal applications are atriums, cathedral ceilings, aircraft hangars, warehouses, sporting arenas, concert halls, and enclosed parking facilities. They are compatible with the MS-9600 Series and MS9200 Series in LiteSpeed® or CLIP mode. Installation of the single-ended reflective design is much quicker than a dual-ended projected beam detector. Alignment is easily accomplished with an optical sight and a two-digit signal strength meter incorporated into the beam detector. Listed for operation from -22°F to 131°F, the BEAM355 and BEAM355S are usable in open area applications where temperature extremes exceed the design limits of other types of smoke detection.

The BEAM355 and BEAM355S are a transmitter/receiver unit and a reflector. When smoke enters the area between the unit and the reflector it causes a reduction in the signal strength. When the smoke level (signal strength) reaches the predetermined threshold, an alarm is activated. The detectors have four standard sensitivity selections as well as two Acclimate® settings. When either Acclimate® setting is selected, the detector's advanced software algorithms automatically adjust to the optimum sensitivity for the specific environment.

The BEAM355S has an integral sensitivity test feature of a filter attached to a servomotor inside the detector optics. Activation of the RTS151 or RTS151KEY remote test stations moves the filter into the pathway of the light beam, testing the detector's sensitivity. This sensitivity test feature allows the user to quickly and easily meet the annual maintenance and test requirements of NFPA 72, without physical access to the detector. The servomotor must be powered by +24 VDC, not SLC power.

FEATURES

- Listed to UL 268, ULC CAN/ULC S529.
- Transmitter/receiver built into same unit.
- Six user-selectable sensitivity levels.
- 16' to 328' (use BEAMLRK beyond 230') protection range.
- Removable plug-in terminal blocks.
- Digital display — no special tools required.
- Built-in automatic gain control compensates for signal deterioration from dust buildup.
- Optional remote test station.
- Optional long-range kit (BEAMLRK) for applications in excess of 230' (70 m).
- Optional multi-mount kit (BEAMMMK) providing ceiling or wall mount capability with increased angular adjustment.
- Optional heater kits (BEAMHK and BEAMHKR) for prevention of condensation (not intended to increase or reduce the specified operating temperature).
- Paintable cover.

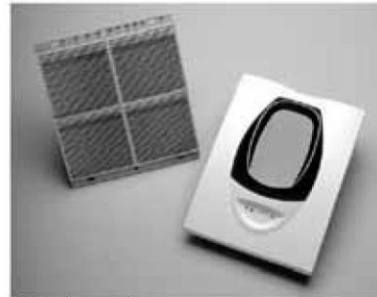

6975reflect.wmf

BEAM355
with
Reflective Plate



6975beammk.wmf

BEAM355
with
BEAMMMK

SPECIFICATIONS

OPERATIONAL SPECIFICATIONS

Protection Range: 16 to 230 feet (5 to 70 m), 230 to 328 feet (70 to 100 m) using optional BEAMLRK kit.

Adjustment Angle: ±10° horizontal and vertical. Note that the optics move independently of the unit.

Sensitivity (6 levels):

NOTE: Sensitivity settings are a feature of specific control panels.

- Level 1 — 25%.
- Level 2 — 30%.
- Level 3 — 40%.
- Level 4 — 50%.
- Acclimate® Level 5 — 30% to 50%.
- Acclimate® Level 6 — 40% to 50%.

Fault Condition (trouble):

- 96% or more obscuration blockage.
- In alignment mode.
- Improper initial alignment.
- Self-compensation limit reached.

Alignment Aid:

- Optical gunsight.
- Integral signal strength indication.
- Two-digit display.

Indicators:

- Alarm — local red LED and remote alarm.
- Trouble — local yellow LED and remote trouble.
- Normal — local flashing green LED.

Test/reset features:

- Integral sensitivity test filter (BEAM355S only, requires external power supply).
- Sensitivity filter (incremental scale on reflector).
- Local alarm test switch.
- Local alarm reset switch.
- Remote test and reset switch (compatible with RTS151 and RTS151KEY test stations).

Smoke Detector Spacing: On smooth ceilings, 30 – 60 feet (9.1 to 18.3 m) between projected beams and not more than one-half that spacing between a projected beam and a sidewall. Other spacing may be used depending on ceiling height, airflow characteristics, and response requirements. See NFPA 72.

ENVIRONMENTAL SPECIFICATIONS

Temperature: -22°F to 131°F (-30°C to 55°C).

Humidity: 10 – 93% RH noncondensing.

ELECTRICAL SPECIFICATIONS

- **Voltage:** 15 to 32 VDC.
- **Average Standby Current (24 VDC):** 2 mA maximum (LED flashing, SLC @ 24 V).
- **Alarm Current (LED on):** 8.5 mA maximum.
- **Trouble Current (LED on):** 4.5 mA maximum.
- **Alignment Current:** 20 mA maximum.
- **External Supply (BEAM355S only):**
Voltage — 15 to 32 VDC
Current — 0.5 A maximum.
- **Remote Output (Alarm):**
Voltage - 15 to 32 VDC (Output voltage same as device input voltage)
Current - 15 mA maximum, 6 mA minimum (Output current is limited by 2.2K ohm resistor)
- **Heater Kit BEAMHK:** Voltage - 15 to 32 V; Current - 92 mA maximum @ 32 V (heater only); Power Consumption - nominal 1.6 W @ 24 V, maximum 3.0 W @ 32 V.
- **Reflector Heater Kit BEAMHKR:** Voltage - 15 to 32 V; Current - 450 mA maximum @ 32 V (per reflector); Power Consumption (per reflector) - nominal 7.7 W @ 24 V, maximum 15.0 W @ 32 V.

MECHANICAL SPECIFICATIONS

Shipping Weight: 3.7 lbs (1.68 kg)

Detector Dimensions: 10.0" H x 7.5" W x 3.3" D (254 mm H x 191 mm W x 84 mm D).

Reflector Dimensions for 16' to 230' (5 to 70m) Applications: 7.9" x 9.1" (200 x 230 mm).

Reflector Dimensions for Applications Beyond 230'/70m: 15.7" x 18.1" (400 x 460 mm).

SENSITIVITY SELECTION

The detector has six sensitivity selections (sensitivity settings are a feature of specific control panels). Each of these selections is only acceptable over a specific distance separation between the detector and the reflector per UL 268. The chart below determines which selections are acceptable for your installed distance. The sensitivity of the detector can be set only when the housing is removed and the detector is not in the fine adjustment step of the alignment mode, indicated by the illumination of the dual digital display. To set the sensitivity, depress the sensitivity button one time. See Switch Locations diagram. Once the switch is pressed, the digital display will illuminate and read the current sensitivity setting in percent obscuration. To change the sensitivity, continue to depress the sensitivity switch until the desired setting is achieved. The digital display will turn off automatically if no further switch presses occur.

Sensitivity Setting	Percent Obscuration	Display Reading	Acceptable DISTANCE between Detector and Reflector (ft)	Acceptable DISTANCE between Detector and Reflector (m)
Level 1	25%	25	16.4 to 120	5.0 to 36.6
Level 2	30%	30	25 to 150	7.6 to 45.7
Level 3	40%	40	60 to 220	18.3 to 67
Level 4	50%	50	80 to 328	24.4 to 100
Acclimate® Level 1	30% to 50%	A1	80 to 150	24.4 to 45.7
Acclimate® Level 2	40% to 50%	A2	80 to 200	24.4 to 67

In addition to the four standard sensitivity selections, the detector has two Acclimate® settings. When either Acclimate® setting is chosen the detector will automatically adjust its sensitivity using advanced software algorithms to select the optimum sensitivity for the environment. The sensitivity will be continuously adjusted within the ranges specified in the chart above.

Total obscuration can be converted to percent per foot, assuming uniform smoke density for the entire length of the beam. The chart below converts total obscuration percent per foot for all acceptable sensitivity settings.

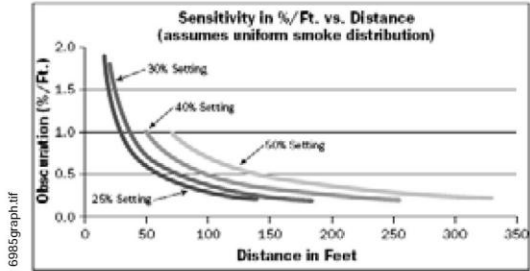

Total Obscuration

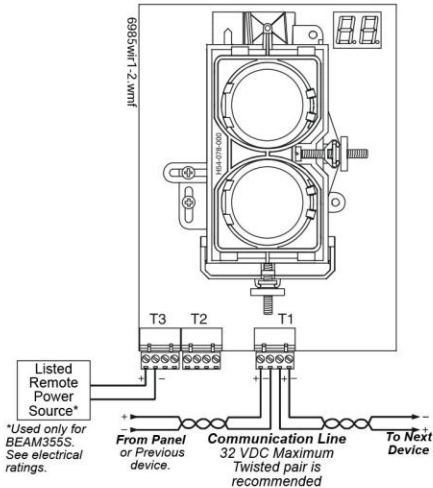

Wiring Diagram

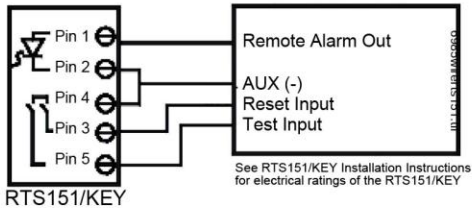

Wiring Diagram with RTS151/KEY

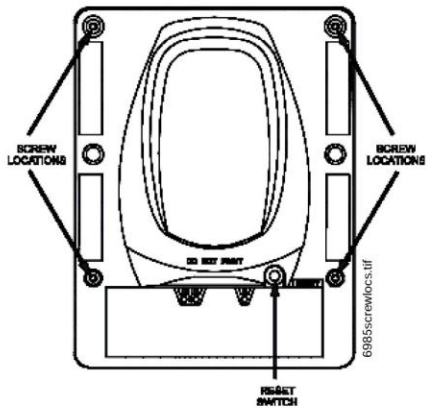

Housing Screw Locations

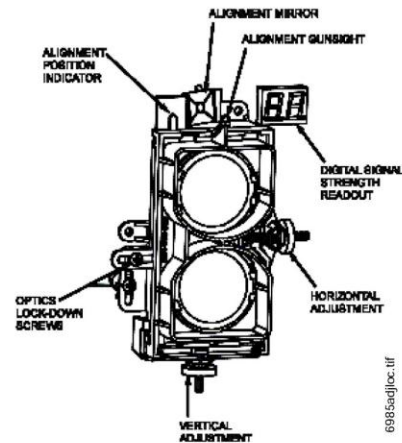
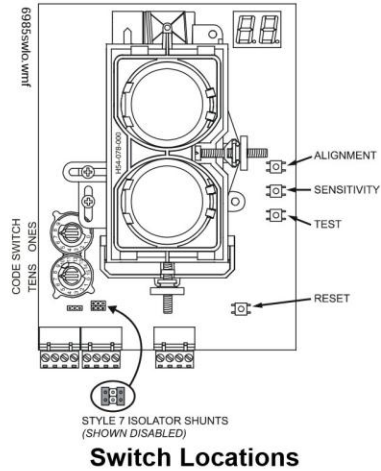

Alignment and Adjustment Locations

PARTS LIST

- Item Quantity**
- Transmitter/Receiver Unit 1
 - Paintable Trim Ring 1
 - Reflector 1
 - Plug-In Terminal Blocks 3
 - Isolator Shunts 2
 - Instruction Manual 1
 - Orange Sticky Paper 1

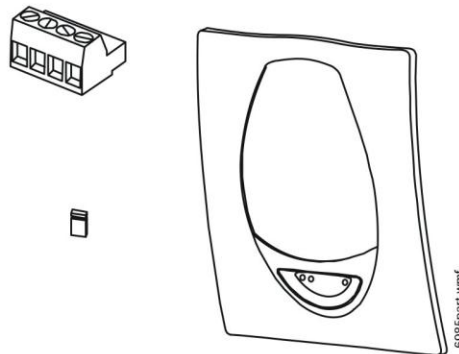

AGENCY LISTINGS AND APPROVALS

These listings and approvals apply to the devices specified in this document. In some cases, certain modules or applications may not be listed by certain approval agencies, or listing may be in process. Consult factory for latest listing status.

- **UL Listed:** S1059
- **ULC Listed:** S1059
- **CSFM:** 7260-0075:209
- **MEA:** 143-04-E
- **FM Approved**

PRODUCT LINE INFORMATION

- BEAM355:** Intelligent beam smoke detector
- BEAM355S:** Intelligent beam smoke detector with integral sensitivity test.
- BEAMLRK:** Long range accessory kit (required for applications in excess of 230 ft/70 m).
- BEAMMMK:** Multi-mount kit (provides ceiling or wall mount capability with increased angular adjustment).
- BEAMSMK:** Surface-mount kit.
- RTS151:** Remote test station.
- RTS151A:** Same RTS151 with ULC listing.
- RTS151KEY:** Remote test station with key lock.
- RTS151KEYA:** Same as the RTS151KEY with ULC listing.
- BEAMHK:** Heating kit for use with the transmitter/receiver unit of BEAM355S. For prevention of condensation.
- BEAMHKR:** Heating kit for use with the reflector on BEAM355S. For prevention of condensation
- 6500-MMK:** Heavy-duty multi-mount kit for installations prone to vibration or where there is difficulty mounting the set angle. When installed with the transmitter/receiver unit, the 6500-SMK must be used as well.
- 6500-SMK:** Surface-mount kit (required when using 6500-MMK to mount transmitter/receiver).



6075beammmk.jpg

BEAMMMK

(ceiling or wall mount kit sold separately)



rts151.wmf

RTS151



rts151key.wmf

RTS151KEY



6985hk.tif

BEAMHK