

MORLEY  **IAS**
FIRE SYSTEMS

by Honeywell

ZX1Se
ZX2Se
ZX5Se
ZX10Se

Document No. 996-174-000-2, Issue 02

installation manual

This manual should not be left with the end user.

ZX Fire Alarm Control Panels MORLEY-IAS

Table of Contents

1	INTRODUCTION.....	1
1.1	NOTICE.....	1
	WARNINGS AND CAUTIONS.....	1
1.3	NATIONAL APPROVALS.....	2
1.4	EN54	2
	INFORMATION	2
2	UNPACKING.....	4
3	INSTALLATION.....	5
	INSTALLING THE ENCLOSURE	5
3.1.1	Removing the Chassis.....	5
3.1.2	Mounting the Enclosure to the Wall.....	5
3.1.3	Remounting the Chassis.....	5
	DIMENSIONS AND FIXING POINTS.....	6
3.3	IDENTIFICATION OF PARTS	7
3.3.1	CPU Board.....	8
3.3.2	Display / Keyboard.....	8
3.3.3	Base Card.....	8
3.3.4	Zone Extender Card (ZX5Se Option Only).....	8
3.3.5	Internal Printer (ZX5Se /ZX10Se Option Only).....	8
3.4	EXTERNAL CONNECTIONS.....	9
3.1.1	Mains Power Input.....	9
3.4.1.1	ZX1Se / ZX2Se Arrangement.....	9
3.4.1.2	ZX5Se Arrangement	9
3.4.1.3	ZX10Se Arrangement	10
3.4.1.4	Mains Cable Glands.....	10
3.1.2	Battery Installation	11
3.4.2.1	General Introduction.....	11
3.4.2.2	ZX1Se / ZX2Se Arrangement.....	11
3.4.2.3	ZX5Se Arrangement	12
3.4.2.4	General Battery Connection.....	12
3.1.3	Detection Loops.....	13
3.4.3.1	Loop Wiring Installation.....	14
3.4.3.2	EMC Compliance	15
3.4.3.3	Adding Loop Driver Cards.....	16
3.4.3.4	Panel Loop Loading	16
3.1.4	Sounder Circuits	17
3.4.4	Auxiliary Relay Outputs.....	19
3.4.6	Auxiliary Supply Output	20
3.4.7	Panel Networking / Graphics PC Interface.....	21
3.4.7.1	Local Panel Network	21
3.4.7.2	Master Panel to Superior Master Panel	21
3.4.7.3	Panel to Graphics PC.....	21
3.4.8	Peripheral Loop.....	22
3.4.9	RS485 Wiring Arrangements.....	23
3.4.9.1	Daisy Chain Style Installation.....	23
3.4.9.2	Loop Style Installation.....	23
3.4.9.3	EMC Compliance	24
3.4.9.4	Cable Screen – Earth Connections.....	24
3.4.10	High Integrity Loop.....	24

MORLEY-IAS ZX Fire Alarm Control Panels

3.4.11	Group Disable Input.....	25	
3.4.12	Class Change Input.....	25	
3.4.13	Recommended Cables.....	25	
3.4.14	Cable Routing.....	26	
3.5	INSTALLING		EQUIPMENT
		27	
3.5.1	General Introduction.....	27	
3.5.1.1	ZX1Se Arrangement.....	27	
3.5.1.2	ZX2Se Arrangement.....	28	
3.5.1.3	ZX5Se Arrangement.....	28	
			Page i
3.5.2	Loop Driver Cards.....	29	3.5.2.1
	Voltage Selection.....	29	
3.5.2.1.1	ZX1Se / ZX2Se Jumper Settings.....	29	
3.5.2.1.2	ZX5Se Jumper Settings.....	30	
3.5.3	485 / 232 Interface Cards.....	30	
3.5.3.1	Mounting the Card Directly to the Base Card.....	31	
3.5.3.2	Mounting the Card Above the Loop Driver Module.....	31	
3.5.4	Printer Module (ZX5Se / ZX10Se Only).....	32	
3.5.5	Keyswitch Option (ZX5Se / ZX10Se Only).....	32	
4	STANDBY BATTERY CALCULATIONS.....	33	
4.1	SENSOR CURRENT CALCULATIONS.....	35	
4.1.1	Quiescent Load.....	35	
4.1.2	Alarm Load.....	35	
4.1.3	Adjustment Factors.....	35	
4.2	LOCAL SYSTEMS AMPERE HOUR CALCULATION.....	35	
5	MAINTENANCE.....	36	
5.1	MAINTENANCE SCHEDULE.....	36	
5.1.1	Daily Attention.....	36	
5.1.2	Monthly Attention.....	36	
5.1.3	Quarterly Attention.....	36	
5.1.4	Yearly Attention.....	36	
5.2	REPLACEMENT OF COMPONENTS.....	37	
5.2.1	Lithium Standby battery.....	37	
5.2.2	Liquid Crystal Alphanumeric Display.....	37	
5.2.3	Standby Batteries.....	37	
6	SPECIFICATIONS.....	38	
6.1	FUNCTIONAL SPECIFICATIONS.....	38	
6.2	POWER SUPPLY AND CHARGER.....	40	
6.3	RECOMMENDED CABLES.....	42	
7	APPENDIX - ZX10SE INSTALLATION.....	44	
7.1	GENERAL.....	44	
7.2	WARNINGS AND CAUTIONS.....	44	
7.3	NATIONAL APPROVALS.....	44	
7.4	UNPACKING.....	44	7.5
	INSTALLATION.....	44	7.6
	DIMENSIONS AND FIXING POINTS.....	45	
7.7	IDENTIFICATION OF PARTS.....	46	
7.4.1	CPU Card.....	46	7.7.2
	Display / Keyboard.....	46	7.7.3
	Base Card.....	46	7.7.4
	Zone Extender Cards.....	46	
7.7.5	Internal Printer.....	46	
7.8	EXTERNAL CONNECTIONS.....	47	
7.8.1	Mains Power Input.....	47	
7.8.2	Mains Cable Glands.....	48	

ZX Fire Alarm Control Panels MORLEY-IAS

7.9 BATTERY INSTALLATION.....	48	7.10
EXTERNAL WIRING CONNECTIONS.....	49	
7.11 CABLE ROUTING.....	49	
7.12 INSTALLING ADDITIONAL EQUIPMENT	50	
7.13 MAINTENANCE.....	50	
7.14 SPECIFICATION.....	50	
7.14.1 Functional Specifications	50	

Page ii

Table of Figures

FIGURE 1 – PANEL FIXING CENTRES – ZX1Se / ZX2Se.....	6
FIGURE 2 – PANEL FIXING CENTRES - ZX5Se	6
FIGURE 3 – ENCLOSURE ARRANGEMENT – ZX1Se / ZX2Se	7
FIGURE 4 – ENCLOSURE ARRANGEMENT – ZX5Se	7
FIGURE 5 – MAINS INPUT ARRANGEMENT – ZX1Se / ZX2Se.....	9
FIGURE 6 – MAINS INPUT ARRANGEMENT – ZX5Se	10
FIGURE 7 – ZX1Se / ZX2Se BATTERY INSTALLATION	11
FIGURE 8 – ZX5Se BATTERY INSTALLATION.....	12
FIGURE 9 – SLC CONNECTIONS	14
FIGURE 10 – LOOP WIRING WITHOUT ISOLATORS	14
FIGURE 11 – LOOP WIRING WITH ISOLATORS– PREFERRED ALTERNATIVE	15
FIGURE 12 – SLC LOOP – EMC ABSORBER INSTALLATION	15
FIGURE 13– ADDING LOOP DRIVER CARDS – ZX1Se / ZX2Se / ZX5Se	16
FIGURE 14– SOUNDER TERMINAL CONNECTION POINTS – ZX1Se / ZX2Se.....	17
FIGURE 15– SOUNDER TERMINAL CONNECTION POINTS – ZX5Se	17
FIGURE 16– SOUNDER WIRING.....	18
FIGURE 17 – RELAY OUTPUT TERMINAL CONNECTION POINTS – ZX1Se / ZX2Se.....	19
FIGURE 18 – RELAY OUTPUT TERMINAL CONNECTION POINTS – ZX5Se	19
FIGURE 19 – AUXILIARY OUTPUT CONNECTIONS – ZX1Se / ZX2Se	20
FIGURE 20 – AUXILIARY OUTPUT CONNECTIONS – ZX5Se.....	20
FIGURE 21 – TYPICAL RS485 – ‘DAISY CHAIN’ WIRING.....	23
FIGURE 22 – TYPICAL RS485 – ‘LOOP’ WIRING.....	23
FIGURE 23 – RS485 LOOP – EMC ABSORBER INSTALLATION.....	24
FIGURE 24 – RS485 SCREEN – EARTH ARRANGEMENT.....	24
FIGURE 25 – RECOMMENDED CABLE ROUTING ARRANGEMENT – ZX1Se / ZX2Se.....	26
FIGURE 26 – RECOMMENDED CABLE ROUTING ARRANGEMENT – ZX5Se	26
FIGURE 27 – POSITIONS FOR ADDITIONAL BOARDS – ZX1Se.....	27
FIGURE 28 – POSITIONS FOR ADDITIONAL BOARDS – ZX2Se.....	28
FIGURE 29 – POSITIONS FOR ADDITIONAL BOARDS – ZX5Se.....	28
FIGURE 30 – MOUNTING THE LOOP DRIVER.....	29
FIGURE 31 – MOUNTING THE RS485 / RS232 MODULE.....	31
FIGURE 32 – MOUNTING THE RS485 / RS232 MODULE.....	31
FIGURE 33 – PANEL FIXING CENTRES – ZX10Se	45
FIGURE 34 – ENCLOSURE ARRANGEMENT ZX10Se.....	46
FIGURE 35 - MAINS INPUT ARRANGEMENT – ZX10Se.....	47
FIGURE 36 – ZX10Se BATTERY INSTALLATION – 17AH OR GREATER.....	48
FIGURE 37 – RECOMMENDED CABLE ROUTING ARRANGEMENT – ZX10Se	49

Table of Tables

TABLE 1 – PACKING CONTENTS LIST.....	4
TABLE 2 - LOOP DRIVER PART NUMBERS	8
TABLE 3 – MAXIMUM LOOP LENGTHS	13
TABLE 4 – LIST OF COMPATIBLE PERIPHERAL DEVICES.....	22
TABLE 5 – JUMPER SETTING FOR LOOP VOLTAGE.....	29
TABLE 6 – JUMPER SETTING FOR LOOP VOLTAGE.....	30
TABLE 7 – CURRENT RATING CHART – ZX1Se / ZX2Se	33

MORLEY-IAS ZX Fire Alarm Control Panels

TABLE 8 - CURRENT RATING CHART - ZX5Se.....	34
TABLE 9 – ZX1Se / ZX2Se FUNCTIONAL SPECIFICATIONS.....	38
TABLE 10 – ZX5Se FUNCTIONAL SPECIFICATIONS.....	39
TABLE 11 – ZX1Se / ZX2Se POWER SUPPLY AND CHARGER SPECIFICATIONS	40
TABLE 12 - ZX5Se POWER SUPPLY AND CHARGER SPECIFICATIONS	41
TABLE 13 – ZX10Se FUNCTIONAL SPECIFICATION.....	50
TABLE 14 – ZX10Se POWER SUPPLY AND CHARGER SPECIFICATION.....	51

This page intentionally blank

ZX Fire Alarm Control Panels MORLEY-IAS

Page iv

1 Introduction

1.1 Notice

- The material and instructions covered in this manual have been carefully checked for accuracy and are presumed to be correct. However, the manufacturer assumes no responsibility for inaccuracies and reserves the right to modify and revise this document without notice.
- These instructions cover the installation of the Fire Alarm Control Panels. Refer to the User Manual (P/N 996-182-000-X) details of how to operate the system and refer to the Commissioning Manual (P/N 996-175-000-X) for information on functions.
For use with software for version 837 onwards programming and Level 3
- The ZX1Se, ZX2Se, ZX5Se and ZX10Se Fire Alarm Control Panels are 1, 1-2, 1-5 and 1-10 loop panels for use with analogue addressable devices from the following detector manufacturer ranges:



1.2 Warnings and Cautions



These instructions contain procedures to follow in order to avoid injury and damage to equipment. It is assumed that the user of this manual is a suitably trained installer who is familiar with the relevant regulations.



Electro-static Sensitive Devices.

Take suitable ESD precautions when removing or installing printed circuit boards.



This panel is CE Marked to show that it conforms to the requirements of the following European Community Directives:

- **The EMC Directive 2004/108/EEC, by the application of the following EMC Standards:**
 - EN 61000-6-3: Electronic compatibility (EMC) generic emission standard for Residential, Commercial and light industrial environments.
 - EN 50130-4: EMC Product family standard: Immunity requirements for components of fire, intruder and social alarm systems.
- **The Low Voltage Directive 2006/95/EE, by the application of the safety standard:**
 - EN 60950-1: Safety of information technology equipment.
- **The Construction Products Directive 89/106/EEC, by the application of the following standards:**
 - EN54-2: Fire detection and fire alarm systems – control and indicating equipment.

MORLEY-IAS ZX Fire Alarm Control Panels

EN54-4:



Fire detection and fire alarm systems – Power supply equipment

- WEEE Directive: must be disposed Authority to and electronic

This product contains electrical and electronic equipment that of suitably at the end of its service life. Contact your Local determine the procedures for the disposal of waste electrical equipment. In particular, note that the CPU card contains a lithium battery. This battery must be removed and disposed of separately. See Section 5.2.1, Lithium Standby Battery for further information.



EN54-2 13.7
Maximum of 512 sensors / manual call points per panel.

further information.

- The ZX1Se, ZX2Se and ZX5Se range of panels has many features, which if used inappropriately, may contravene the requirements of EN54. Where such a possibility may arise, a suitable warning is given with brief details of the EN54 requirement and the relevant section it pertains to. A typical EN54 non-compliance warning is illustrated.

- The ZX10Se fire control panel, which comprises two networked ZX5Se panels within a single enclosure, has a maximum limit of 1024 sensors /call points.

1.3 National Approvals

- This equipment must be installed in accordance with these instructions and the appropriate national, regional and local fire systems installation regulations specific to the country and location of the installation. Consult with the appropriate Authority Having Jurisdiction (AHJ) for confirmation of the requirements.



All equipment is to be installed in accordance with the appropriate standards for the country and area of installation.

- This equipment must be installed in accordance with these instructions and the appropriate national, regional and local wiring regulations. In the UK the wiring must conform to the requirements of the latest edition of the IEE Wiring Regulations.

1.4 EN54 Information



- This Fire Control Panel complies with the requirements of EN54-2/4. In addition to the basic requirements of EN54, the panel conforms to the following optional functions.

Option	EN54-2 Clause
Indications:	
Fault signals from points	8.3
Controls:	
Delays to outputs	7.11.1
Manual or automatic switching of delays to outputs	7.11.2
Dependency on more than one alarm signal: Type C	7.12.3
Disablement of each address point	9.5
Test condition	10
Outputs:	
Outputs to fire alarm device(s)	7.8

ZX Fire Alarm Control Panels MORLEY-IAS



- The power supplies for the ZX1Se, ZX2Se, ZX5Se and ZX10Se range of panels comply with the following clauses of EN54-4.

ZX1Se, ZX2Se, ZX5Se & ZX10Se Power Supply Functions	EN54-4 Clause
Derive power supply from main power source	5.1
Derive power supply from a standby battery source	5.2
Charge and monitor the standby battery source	5.3
Detect & signal power supply faults	5.4



- In addition to the functions required by EN54-2, the panel supports a number of ancillary functions that are not required by EN54. These are outlined below:

Ancillary Function	Manual Section
Auxiliary supply output	3.4.6
Panel network output ports (Port C)	3.4.7, 3.5.1.1 & 3.5.1.3
Master panel to superior master panel output port connections (Port B - ZX5Se and ZX10Se only)	3.4.7.2, 3.5.1.1 & 3.5.1.3
Panel to graphics PC output port connections (Port B – ZX5Se and ZX10Se only)	3.4.7.3, 3.5.1.1 & 3.5.1.3
Peripheral loop output & supported devices (Port D)	3.4.8, 3.5.1.1 & 3.5.1.3
High integrity 485 Loop	3.4.10 & Hi485 Installation Guide (996-065)
Auxiliary relay outputs	3.4.5
Printer option (ZX5Se and ZX10Se only)	3.5.4
Class Change Input	3.4.12
Group Disable	3.4.11

2 Unpacking

- The ZX1Se, ZX2Se, ZX5Se and ZX10Se Fire Alarm Control Panels are simple to install if the recommended procedures described in this manual are followed. Refer to the Commissioning Manual for details of how to program the system operation.
- Before installing the ZX1Se, ZX2Se, ZX5Se or ZX10Se Fire Alarm Control Panels, first ensure that all the equipment has been received. The packing box should contain the following items.

Item	Component	Part Number	Quantity			
			ZX1Se	ZX2Se	ZX5Se	ZX10Se
1	ZX10Se Fire Alarm Control Panel or	723-001-301	-	-	-	1
	ZX5Se Fire Alarm Control Panel or	721-001-301	-	-	1	-
	ZX2Se Fire Alarm Control Panel or	720-001-301	-	1	-	-
		722-001-301	1	-	-	-

MORLEY-IAS ZX Fire Alarm Control Panels

	ZX1Se Fire Alarm Control Panel					
2	Installation Manual	996-174-000-X	1	1	1	1
3	Commissioning Manual	996-175-000-X	1	1	1	1
4	User Manual	996-182-000-X	1	1	1	1
5	Reference Guide – ZX10Se	996-179-000-X	-	-	-	1
	Reference Guide – ZX5Se	996-178-000-X	-	-	1	-
	Reference Guide - ZX2Se	996-177-000-X	-	1	-	-
	Reference Guide – ZX1Se	996-176-000-X	1	-	-	-
6	Front Door Keys	KEYS - 2233	2	2	2	2
7	Battery Cables Kit	082-073	1	1	1	2
8	EOL Resistor	627-682	2	2	4	8
9	Configuration CD (SPK Disk)	795-082-001-1	1	1	1	1
10	Log Book	996-183-000-1	1	1	1	1

Table 1 – Packing Contents List

- Frame and mount the supplied Reference Guide, on the wall, adjacent to the Panel.

NOTE: The EOL resistors supplied are standard resistors. If EOL resistor assemblies with 150 mm flying leads are required, please order these separately under part number 170-073-682.

3 Installation

3.1 Installing the Enclosure

- Unlock the front door and remove the EOL resistor kit (ZX1Se/2Se) and ferrite absorber and resistor kits (ZX5Se). Store these in a secure place for re-use later.
- If removing the chassis prior to installing the back box, proceed as described below.

3.1.1 Removing the Chassis

- Unplug the ribbon cable between the CPU Board and the Display Board at the CPU Board end. With ZX10Se panels you need to do this for each of the ZX5Se panels.
- Remove the nuts and spring washers holding the chassis to the back box. There are four of each for ZX1Se / ZX2Se, five of each for ZX5Se and ten for the ZX10Se. Store these in a secure place for re-use later.
- For ZX1Se/2Se panels only, disconnect the internal wiring from the AUX, Sounders and Relay connectors at the bottom edge of the Base PCB. DO NOT disconnect the wiring at the Filter PCB. Refer to Section 3.4.14 Cable Routing for correct wiring termination after chassis remounting.
- Carefully remove the chassis assembly. Store in a secure place where it will not be damaged and where it will be kept dry and clean.

Handle the chassis by holding the metalwork only. DO NOT lift it by holding the printed circuit boards or any parts on the circuit boards.

ZX Fire Alarm Control Panels MORLEY-IAS



3.1.2 Mounting the Enclosure to the Wall

The ZX5Se Fire Alarm Control Panel can weigh in excess of 39kg (ZX5Se) and 18kg (ZX2Se) with the batteries fitted. When attaching the enclosure to a surface, use mounting hardware capable of supporting this weight and reinforce the wall if necessary. The ZX10Se can weigh in excess of 76.8kg with two 24Ah batteries fitted.

- Remove the necessary knockouts for the installation cabling.
- Mount the enclosure in the desired location using all four mounting holes (the ZX10Se has 5 holes).
- Use a drill bit diameter 7.0 mm and a suitable 40 mm long expansion plug. Fix the panel to the wall with No. 10 screws length 1½" or M5 screws length 40 mm. DO NOT use countersunk-headed screws.
- Install the external wiring into the enclosure using the appropriate glands / conduit fittings. Sufficient knockouts are provided at the top of the enclosure. If you punch other holes, be sure that they do not interfere with any component mounting positions.
- Use a brush to clean any dust and swarf from inside the enclosure before attempting to remount the chassis assembly.



For details of knockout positions, refer to Section 3.4.14 Cable Routing. Cables must be megger tested before any active devices are fitted and before the connections are made to the terminal blocks.

3.1.3 Remounting the Chassis

- Carefully mount the chassis on to the threaded studs.
- Make sure that the wiring between the Base PCB connectors and Filter PCB is not trapped behind the chassis metalwork (the wiring is secured to the back box side wall to assist with this).
- Secure the chassis to the back box using the nuts and spring washers that were originally removed.
- Plug the ribbon cable between the CPU Board and the Display board back into the CPU Board. The plug and socket are polarised to ensure correct insertion.
- For ZX10Se panels ensure both panels are re-connected as described above.



Handle the chassis by holding the metalwork only. DO NOT lift it by holding the printed circuit boards or any parts on the circuit boards.

3.2 Dimensions and Fixing Points

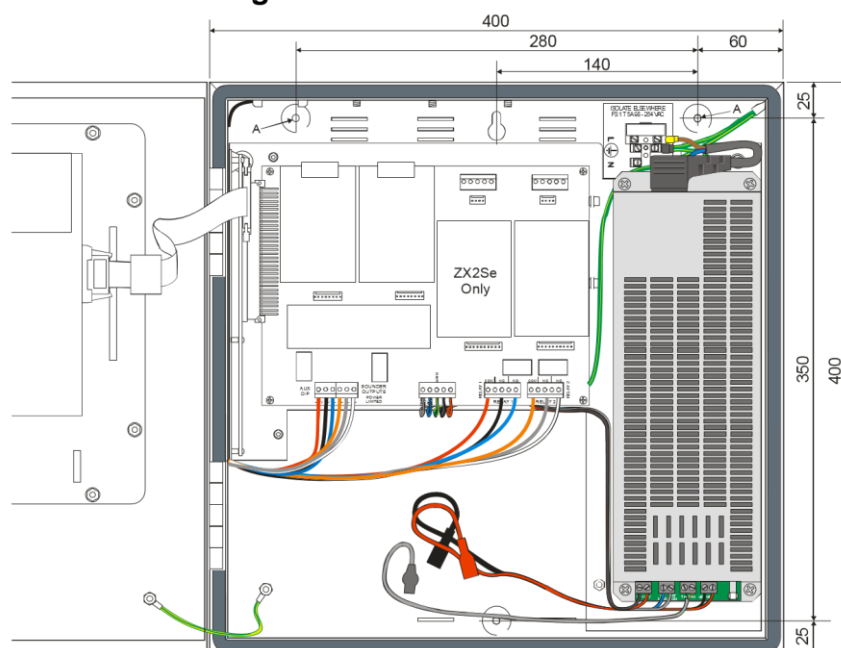

ZX Fire Alarm Control Panels MORLEY-IAS

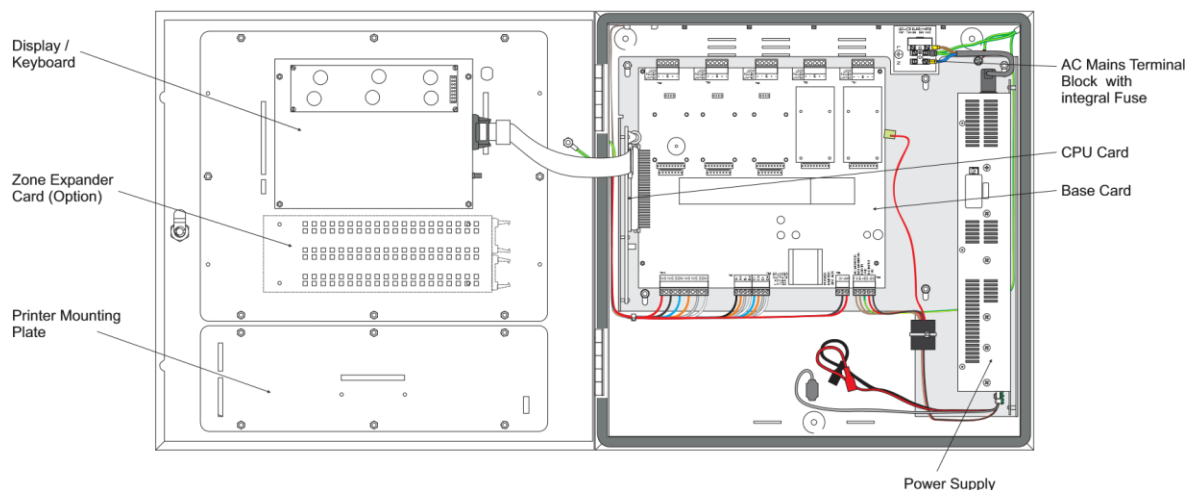

Figure 4 – Enclosure Arrangement – ZX5Se

3.3.1 CPU Board

- The CPU Board controls the operation of the ZX1Se, ZX2Se, ZX5Se and ZX10Se Fire Alarm Control Panels. The operating program is stored in an EPROM mounted in sockets on the board.

3.3.2 Display / Keyboard

- The Display / Keyboard provides the user access to view alarms and control operation of the system.

3.3.3 Base Card

- The base card provides control and wiring of all external connections to the system.
- The base card can be augmented with one (ZX1Se), one to two (ZX2Se), one to five (ZX5Se) or one to ten (ZX10Se) plug-in loop driver modules for connection to the signalling detectors.
- The system can support addressable smoke detectors and loop devices through the use of loop driver boards. The options are as follows:

Loop Device Manufacturer	Loop Card Part No.
Morley-IAS	795-072-100
System sensor	795-068-100
Hochiki	795-058-105
Apollo XP95 / Discovery	795-066-100
Nittan	795-044-001

Table 2 - Loop Driver Part Numbers

- For details of the compatible signalling devices, refer to the relevant installation guide supplied with the loop driver module. At least one loop driver board **MUST** be installed for the unit to operate as a Fire Alarm Control Panel.
- The base card may be augmented by one (ZX1Se), one or two (ZX2Se) or up to three (ZX5Se) plug-in serial interface cards. Up to 6 may be fitted to the ZX10Se FACP – three per ZX5Se panel. The serial interface cards provide for networking of panels and for connection of peripheral devices.

3.3.4 Zone Extender Card (ZX5Se Option Only)

- The ZX5Se FACP may be augmented with an additional Zone LED Indicator card. The ZX10Se may be augmented with two additional zone LED Indicators cards – one in the upper unit and the second in the lower unit. This Zone Expander Card provides FIRE ALARM and FAULT LED indicators.

MORLEY-IAS ZX Fire Alarm Control Panels

- It is available in two options providing, a further 20 zones (40 zones in total) or a further 60 zones (80 zones in total). The model numbers of the units are as follows:
 1. 795-077-020 20 Zone LED Expander
 2. 795-077-060 60 Zone LED Expander
- Refer to the Zone Expander Installation Guide (P/N 996-137) for further information.

3.3.5 Internal Printer (ZX5Se /ZX10Se Option Only)

- The ZX5Se and ZX10Se FACPs may be augmented by the addition of a printer module. This provides printed records of FIRE ALARMS, FAULTS and EVENT LOG.
- Refer to Section 3.5.4 and to the Commissioning Manual for further information.

3.4 External Connections

BEFORE INSTALLATION: Refer to Ratings / Type label located on the inside of the panel.

3.4.1 Mains Power Input

3.4.1.1 ZX1Se / ZX2Se Arrangement

- The ZX1Se and ZX2Se Fire Alarm Control Panels receive power from a 115V - 230V, 50Hz external supply. The current flows through a back-box-mounted fuse. The input mains voltage is converted to a safe extra low voltage (SELV). The location of the power supply ratings label is shown in Figure 5.
- The incoming power feed Earth (Green/Yellow) wire must be connected to the terminal block protective earth connection – middle terminal.
- Connect the neutral (Blue) wire to the terminal marked 'N' and connect the Phase or Live (Brown) wire to the terminal marked 'L'. The terminal block contains an integral fuse.



Open and lock out the circuit breaker before connecting any wiring. Do not power the system until the installation is complete.

Maintain separation between the 115V - 230V, 50Hz and the low voltage wiring. Do not route in the same trunking and keep apart in the enclosure.

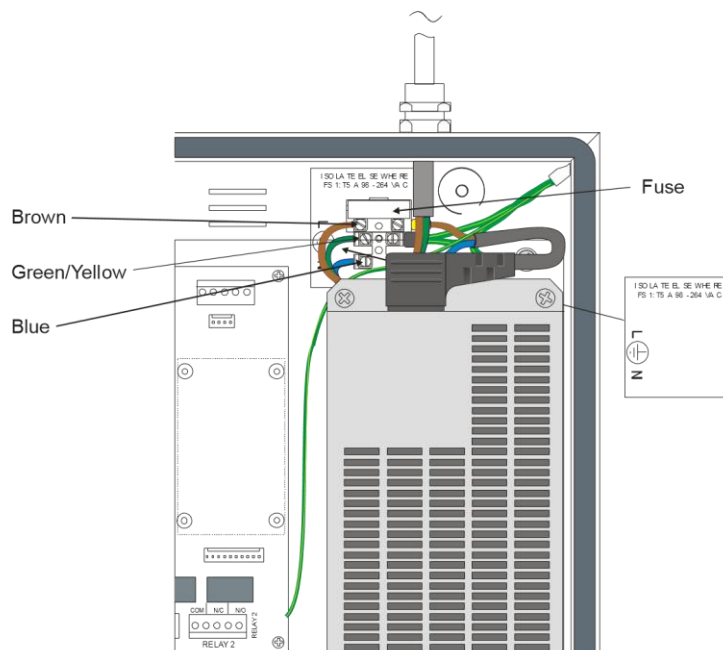

Figure 5 – Mains Input Arrangement – ZX1Se / ZX2Se



ZX Fire Alarm Control Panels MORLEY-IAS



The panel shall be supplied with AC mains power via a readily-accessible, disconnect device ('isolation' switch) to facilitate servicing and be provided with suitable earth fault protection incorporated in the building installation wiring. The minimum cross-sectional area of the mains cable should be 0.75mm and the supply should be fused with a 5A HRC anti-surge fuse.

3.4.1.2 ZX5Se Arrangement



- The ZX5Se Fire Alarm Control Panel receives power from a 115V - 230V, 50Hz external supply. The current flows through a back-box-mounted fuse. The input mains voltage is converted to a safe extra low voltage. The location of the power supply ratings label is shown in Figure 6.
- The incoming power feed Earth (Green/Yellow) wire must be connected to the terminal block protective earth connection – middle terminal.
- Connect the neutral (Blue) wire to the terminal marked 'N' and connect the Phase or Live (Brown) wire to the terminal marked 'L'.

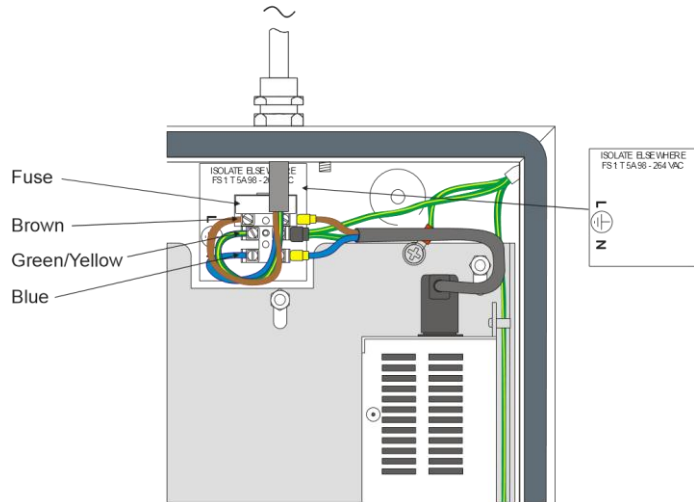

Figure 6 – Mains Input Arrangement – ZX5Se

Open and lock out the circuit breaker before connecting any wiring. Do not power the system until the installation is complete.



Maintain separation between the 115V - 230V, 50Hz and the low voltage wiring. Do not route in same trunking and keep apart in the enclosure.



The panel shall be supplied with AC mains power via a readily accessible disconnect device ('isolation' switch) to facilitate servicing and be provided with suitable earth fault protection incorporated in the building installation wiring. The minimum cross sectional area of the mains cable should be 0.75mm and the supply should be fused with a 5A HRC anti-surge fuse.

3.4.1.3 ZX10Se Arrangement

- Refer to Section 7 Appendix for ZX10Se FACP for installation procedures that vary from the procedures described in Section 3.

3.4.1.4 Mains Cable Glands



The cable gland and cord anchorage bushing used to route the mains cable through the 20mm knockout MUST have a minimum flame retardant rating of 94HB.

- Typical glands / bushings are:

Type Manufacturer Supplier / Part No.

Gland IP65 – Brass M20, Eexd / Eexe Lappcable A2F20S

MORLEY-IAS ZX Fire Alarm Control Panels

Bushing Nylon 66 M20 Black, Rating UL94V-2

Multicomp

Farnell 303-0751

3.4.2 Battery Installation

3.4.2.1 General Introduction

- Refer to the Standby Battery Calculations (Section 4) for the size of the batteries required for a particular installation.
- Refer to Section 5.2.3 for a list of recommended batteries.

Connect mains supply first then connect the batteries.



Do not make the final battery connections until the installation is complete.

CAUTION: RISK OF EXPLOSION - if battery is replaced by incorrect type.

Battery Lead Connections are not power limited.

Ensure the thermistor is affixed to the side wall of one of the batteries, using a suitable silicon sealant.



Before installation.

New Batteries require 'top charging' prior to being put into service. For further information and for a list of recommended batteries, refer to Section 5.2.3.



When the batteries are connected the panel performs a battery wiring integrity test. This test is applied within 10 minutes of the power being applied to the PSU. After that the wiring is tested once per hour. If this test fails 'Battery Low / Charger Fail' is displayed on the LCD. Therefore, if you have a wiring fault or battery fault, the fault will not be cleared until the next test. The best solution is to totally remove power from the PSU and then re-apply.

3.4.2.2 ZX1Se / ZX2Se Arrangement

- Use the cable included in the ancillary kit to connect the negative terminal of battery No.1 to the positive terminal of battery No.2.
- Connect the red wire from the Power Supply to the positive terminal of battery No.1.
- Connect the black wire from the Power Supply to the negative terminal of battery No.2.
- Battery sizes up to 12Ah can be used and should be located in the enclosure as shown in the diagram below.
- When fitting batteries ensure that the wiring between the outputs on the lower edge of the Base PCB and the Filter PCB is routed clear of the batteries as shown below.

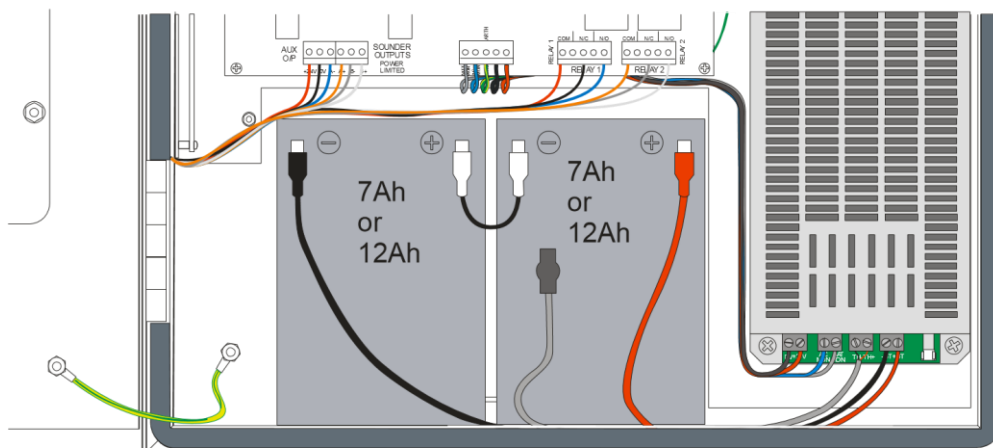

Figure 7 – ZX1Se / ZX2Se Battery Installation

3.4.2.3 ZX5Se Arrangement

ZX Fire Alarm Control Panels MORLEY-IAS

- Included in the packing is a battery cable kit. Use the cable included in this kit to connect the negative terminal of battery No.1 to the positive terminal of battery No.2.
- Connect the red wire from the Power Supply (+BT) to the positive terminal of battery No.1.
- Connect the black wire from the Power Supply (-BT) to the negative terminal of battery No.2.
- The standby batteries should be located in the enclosure as shown in the diagrams opposite.
- For battery sizes greater than 12Ah, it may be necessary to cut off the spade terminals connected to the battery cables. These should be replaced by connector fixings appropriate to the installed batteries.
- When 24Ah batteries are installed take care not to damage or stress the wiring between the lower connectors and the PSU and filter PCB.

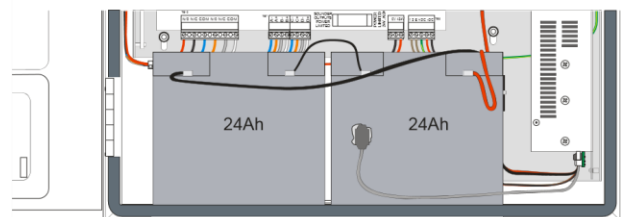
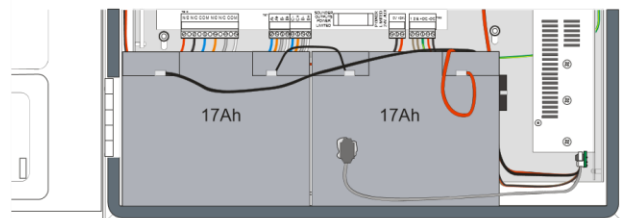
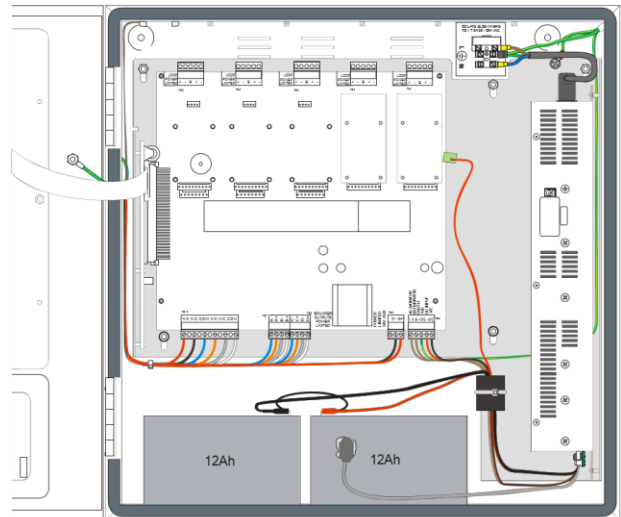
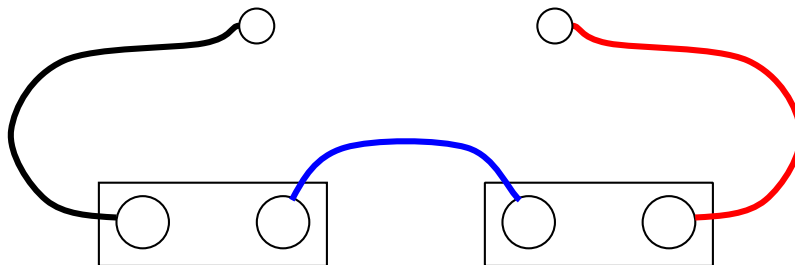

Figure 8 – ZX5Se Battery Installation

- NOTE: When fitting 17Ah or 24Ah batteries there is insufficient space for fitting the internal printer module. In such cases the batteries should be fitted in a separate battery box (797-078) installed adjacent to the ZX Series FACP.

3.4.2.4 General Battery Connection



3.4.3 Detection Loops

- The control panel supports analogue detectors with a digital, data transmission system. It provides power and communicates with the initiating devices over a two-wire circuit.
- Depending on protocol, it is possible for up to 1000 addressable input points to be connected to the panel.
- To comply with EN54-2 requirements, a maximum of 512 sensors / MCPs (input points) only should be connected to the control panel across all analogue detection loops (the limit for the ZX10Se is

MORLEY-IAS ZX Fire Alarm Control Panels

1024 as it comprises two ZX5Se FACPs). This limit includes any conventional detectors / call points connected to the system via zone monitors.

The detection circuit should



EN54-2 13.7

Maximum of 512 sensors / MCPs per panel.



be separated from other cable runs to minimize the risk of external interference. Under extremely noisy conditions, twisted pair wire is recommended to reduce interference.

The Detection Loop Circuits are supervised and power limited.

•Shielded cable should be used for all detection (SLC) circuits. It is important that the shield is always terminated to a good earth connection at both ends of the loop. Mineral insulated copper cable (MICC) is recommended for the best screening purposes. However, most of the established brands of fire-related, screened cables are suitable. Refer to Section 3.4.13 for a list of recommended cables.

- The core size, length of wiring run and detection circuit loading will produce a voltage drop along the length of the cable. To determine if the installed loop driver can fully support the planned loop configuration, use the detector manufacturers' calculations for voltage and capacitance.



ALWAYS check that conductors of appropriate diameter are used so that the voltage at the detectors is within the detector manufacturer's specification.

The maximum permitted impedance for the SLC Loop is dependent on the loop driver card fitted and loop loading conditions. Please refer to the loop and battery calculator tool for specific recommendations.

- The following table lists the maximum recommended cable loop lengths for each detection loop type. Wiring to external devices should follow the appropriate manufacturer's instructions. Again, refer to the loop and battery calculator tool for site-specific recommendations.

Loop Driver	Maximum Loop Length			
	MICC 1.5mm	18 AWG	16 AWG	14 AWG
Morley-IAS	2 km	1 km	1.5 km	2 km
System Sensor	2 km	1 km	1.5 km	2 km
Apollo	2 km	1 km	1.5 km	2 km
Hochiki	2 km	1 km	1.5 km	2 km
Nittan	1 km	0.8km	1 km	1 km

Table 3 – Maximum Loop Lengths

- NOTE 1: Cable runs in excess of 2km are not recommended. Otherwise, cable capacitance (Max. 0.5µF per loop) and inductance may start to interfere with data transmission. For systems with Nittan detectors, cable runs should not exceed ½ km. Refer to the cable manufacturer's quoted figures for maximum cable capacitance.
- The SLC (detector) circuits should be installed as loops with or without isolator modules. The wiring details are as described below.

For best results and system integrity:

The detection loop circuit should be wired as a loop with short circuit isolators. This allows the system to still function in the event that a section of the cable becomes short-circuited. It is recommended that short-circuit isolators be fitted to the detection loop to prevent an external short circuit from removing more than 32 addressable points from the system.

- The detection loop connections are made on the terminal blocks at the top of the base card.



EN54-2 12.5.2

Maximum of 32 sensors / MCP's between Isolators.

els MORLEY-IAS

3.4.3.1 Loop Wiring Installation

- Form the loop by taking wires from the negative terminals, at one side of the on the base card – see opposite.
- Proceed with installing wiring, around the connecting all devices – see below.
- Return the wiring to the positive and terminals at the other side of the connector card.
- Ensure that all devices connected to the correctly oriented for positive and negative
- Refer to the detector manufacturers' data supplied with the signalling device.

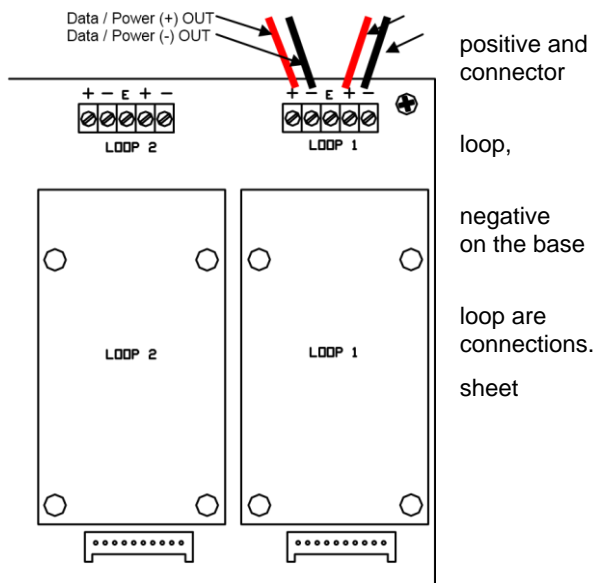

Figure 9 – SLC Connections

FACP Connections

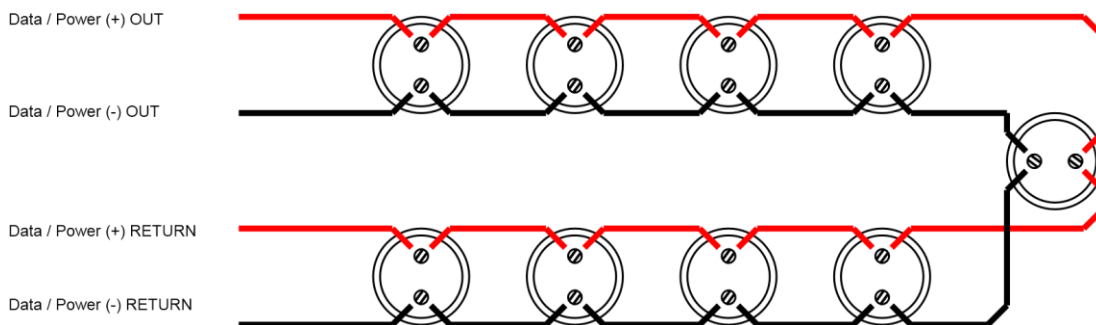

Figure 10 – Loop Wiring without Isolators

- It is recommended that Short Circuit Isolators be installed. Install the isolators at strategic points in the loop (i.e. zonal boundaries) to prevent an external short circuit from removing more than 32 addressable points from the system.
- Note: The loop driver modules have built-in isolators so it is not required to place isolator modules on the outputs of the FACP.
- Refer to the following diagram for information.

FACP Connections

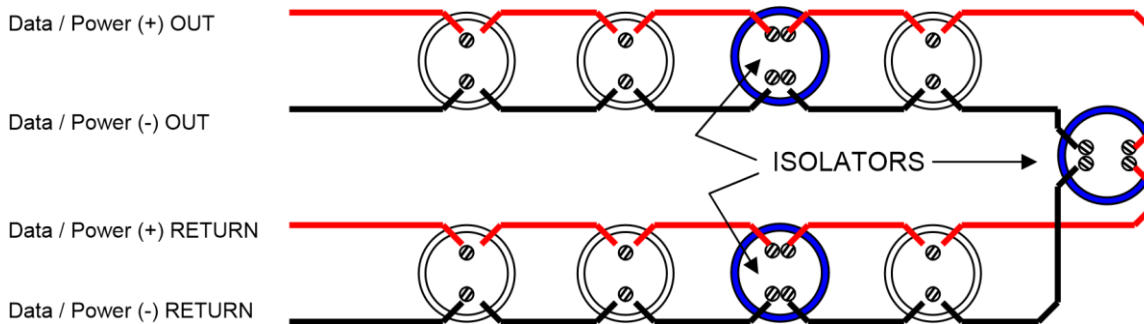

Figure 11 – Loop Wiring with Isolators– Preferred Alternative

MORLEY-IAS ZX Fire Alarm Control Panels

DO NOT loop wiring under any terminals.

EN54-2 requires that an isolator must be sited between each zone. You may use more than this, however, you must ensure that the loop wiring is broken at each isolation point.



3.4.3.2 EMC Compliance



For EMC Compliance, fit the Ferrite Absorbers supplied with the loop driver board earth stud on inner, top wall of back box - keep length as short as possible around the SLC Loop cables.

Cables should be screened and should be terminated in appropriate glands to meet local wiring codes and to preserve the integrity of the screen connection. The cable screen is to be clamped inside the cable gland, which must be fitted to ensure a 360° bond is formed with the metal of the back box. Alternatively, terminate the cable screens (drain wires) at the nearest

Connect Earth drain wire of cables to nearest earth stud on inner, top wall of back box - keep length as short as possible

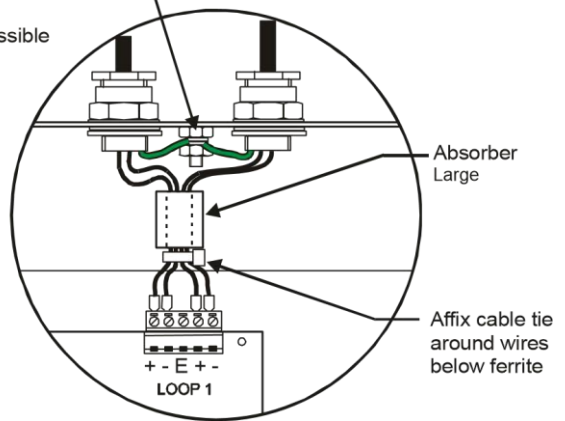

earth stud provided on the inner top surface of the back box.

The figure opposite shows the arrangement for a typical installation.

Figure 12 – SLC Loop – EMC Absorber Installation

3.4.3.3 Adding Loop Driver Cards.

- The ZX1/2Se Base board can be configured to provide the required +35V to power up to 2 loop cards. However, the ZX5Se requires a +35V supply provided by the flying lead for up to 5 ULD loop cards.
- Connect the spare cable from the PSU wiring loom to either of the two connections shown on the Loop driver card, then use the supplied cable to 'daisy chain' subsequent Loop drivers if required. No further connection is required for the last Loop driver card and the supplied cable can be discarded.

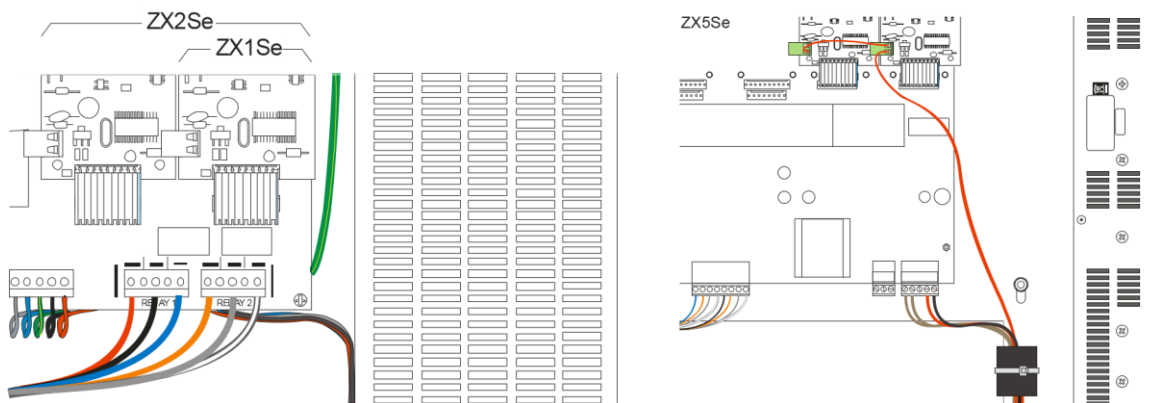

Figure 13– Adding Loop Driver Cards – ZX1Se / ZX2Se / ZX5Se

ZX Fire Alarm Control Panels MORLEY-IAS

3.4.3.4 Panel Loop Loading

- Care must be taken to ensure that the number of signalling loop devices (inputs and outputs) installed does not exceed the power supply ratings of each individual loop driver board and of the panel (all loops) in both quiescent and alarm conditions.
1. Loop Driver Board Load (Refer to the documentation supplied with the loop driver)
 2. Overall Panel Load (Refer to Specification Tables – Section 6).

3.4.4 Sounder Circuits

- The ZX1Se and ZX2Se Fire Alarm Control Panels have two power-limited and supervised sounder circuits, identified as sounder circuits A and B.
- The ZX5Se Fire Alarm Control Panel has four power-limited and supervised sounder circuits, identified as sounder circuits A, B, C and D.
- Each circuit has a maximum rating of 1 Amp. This is the maximum allowed across both sounder circuits (ZX1Se and ZX2Se). The maximum allowed across all four ZX5Se sounder circuits is 2A. Note: The sounder current available depends on the **complete** alarm load for the panel and **must** be verified by the Loop & Battery Calculator.
- Each sounder output is monitored for open and short circuits. An end-of-line (EOL) resistor (6k Ω , 0.5W minimum, P/N 170-073-682) must be fitted to the last sounder on the circuit.
- Each sounder should have an integral blocking diode that prevents the sounder from consuming any power in the normal monitoring position. The polarity of the sounder output is reversed when the sounder circuit is energised. This allows the sounder to turn on.

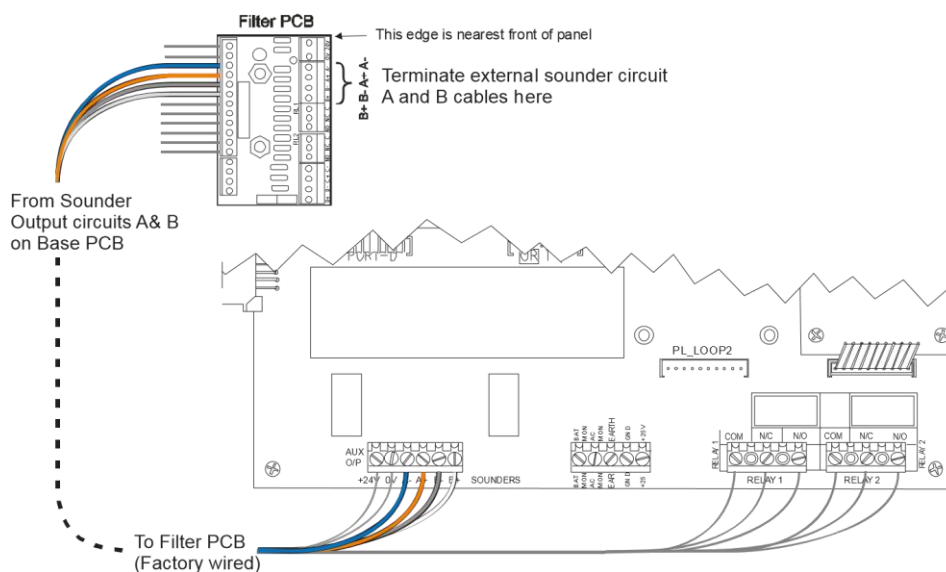

Figure 14– Sounder Terminal Connection Points – ZX1Se / ZX2Se

MORLEY-IAS ZX Fire Alarm Control Panels

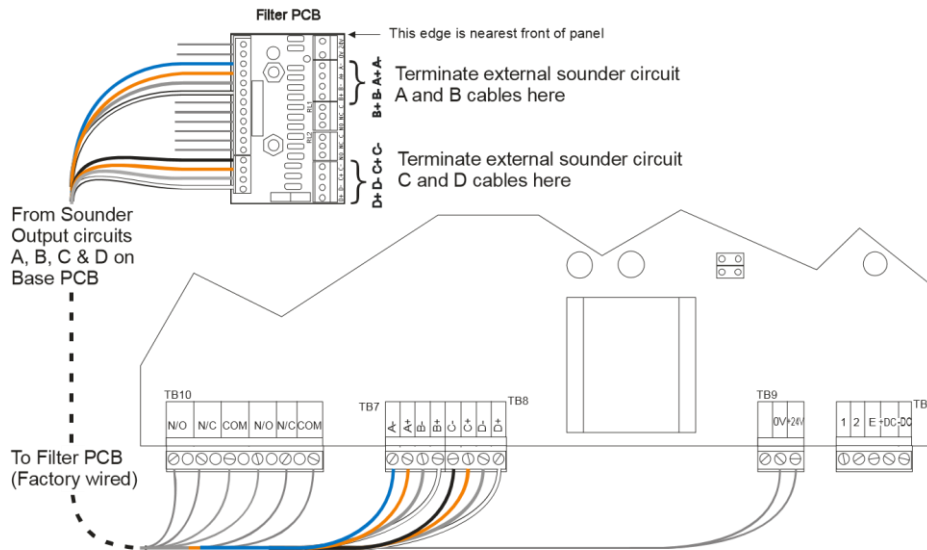

Figure 15– Sounder Terminal Connection Points – ZX5Se

- Any other devices connected to sounder outputs must be suppressed and polarized.
- Refer to Section 3.4.13 for a list of recommended cables.

FACP Connections (made at Filter PCB)

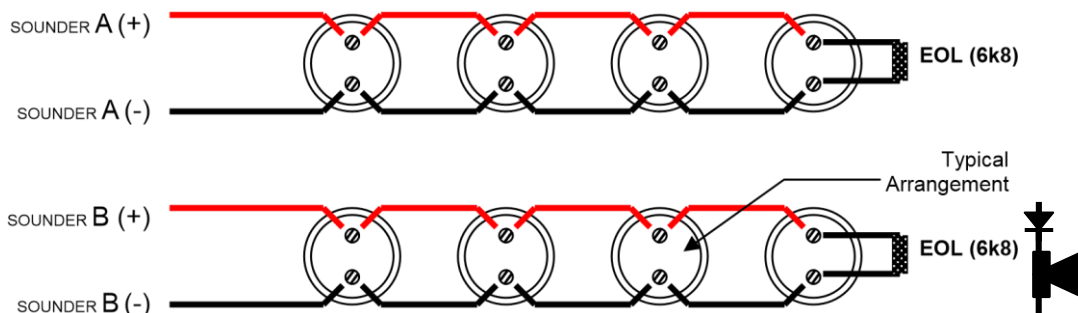

Figure 16– Sounder Wiring

Note: Wiring of sounder circuits C and D for the ZX5Se would be the same.

- Terminate the Sounder circuit wiring at the Filter PCB installed at the left-hand side of the inside of the top cover of the back box. Refer to the figure at the top of the previous page for wiring connection details to the Filter PCB.
- Cable runs in excess of 1km (3200') are not recommended. Otherwise, the capacitance and inductance of the cable may affect the performance of the system.
- Always check that conductors of appropriate diameter are used so that the voltage of all sounders is within the manufacturer's specification when the panel is operating under AC Mains failure and minimum battery voltage conditions (Refer to Table 11 – ZX1Se / ZX2Se Power Supply and Charger Specifications and Table 12 - ZX5Se Power Supply and Charger Specifications for minimum panel output voltage).

3.4.5 Auxiliary Relay Outputs

- The ZX1Se, ZX2Se and ZX5Se Fire Alarm Control Panels have two unsupervised relay outputs, with volt-free (dry contact), changeover contacts. The ZX10Se has four of these relays.
- The contacts are rated at 30V AC/DC, 1 Amp.
- Relay 1 is normally held in an energized state. It will de-energize under fault conditions.

ZX Fire Alarm Control Panels MORLEY-IAS

- Terminate the Auxiliary Relay circuit wiring at the Filter PCB installed at the left-hand side of the inside of the top cover of the back box. Refer to the figure below for wiring connection details to the Filter PCB.



EN54-2 8.8
Fault Output:
Relay 1 is configured for failsafe operation as standard.

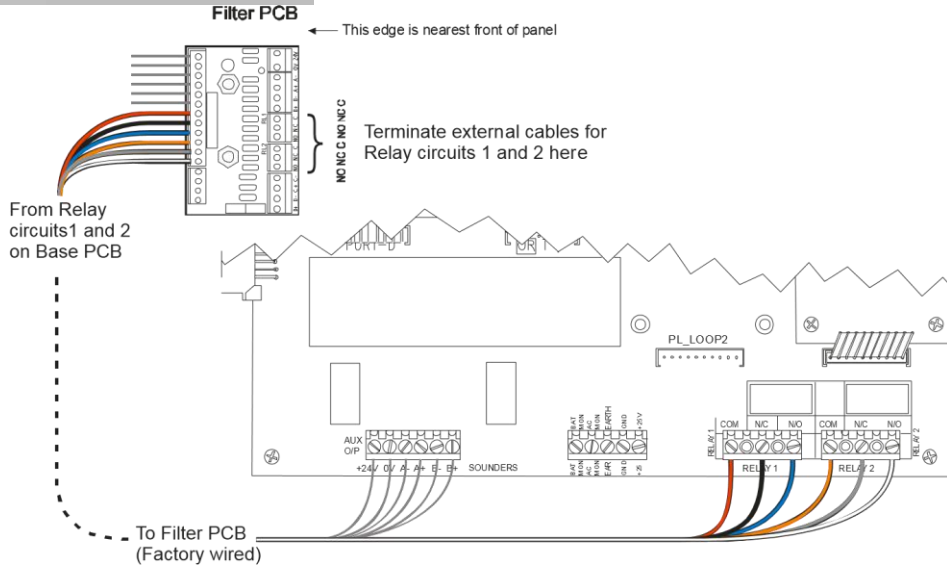

Figure 17 – Relay Output Terminal Connection Points – ZX1Se / ZX2Se

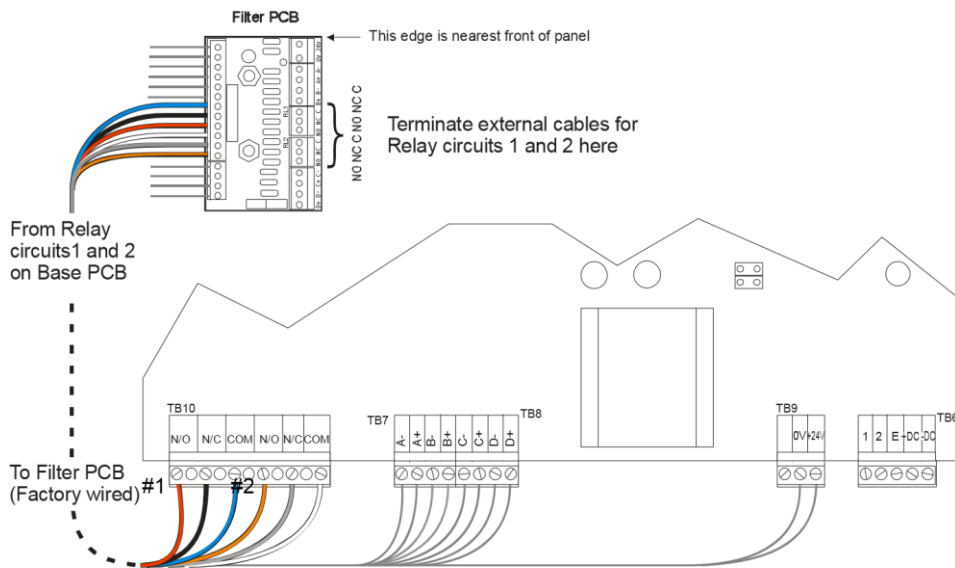

Figure 18 – Relay Output Terminal Connection Points – ZX5Se



DO NOT connect non-power limited wiring to the relay contacts.

3.4.6 Auxiliary Supply Output

- The ZX1Se, ZX2Se, ZX5Se and ZX10Se Fire Alarm Control Panels have a power-limited, unsupervised auxiliary (AUX O/P) 24V-output supply rated at 340mA maximum.

MORLEY-IAS ZX Fire Alarm Control Panels

- This supply can be used to power Remote Annunciator (Repeater) units and other peripheral loop units or other signalling loop units.
- Terminate the Auxiliary Supply Output circuit wiring at the Filter PCB installed at the left-hand side of the inside of the top cover of the back box. Refer to the figure below for wiring connection details to the Filter PCB.

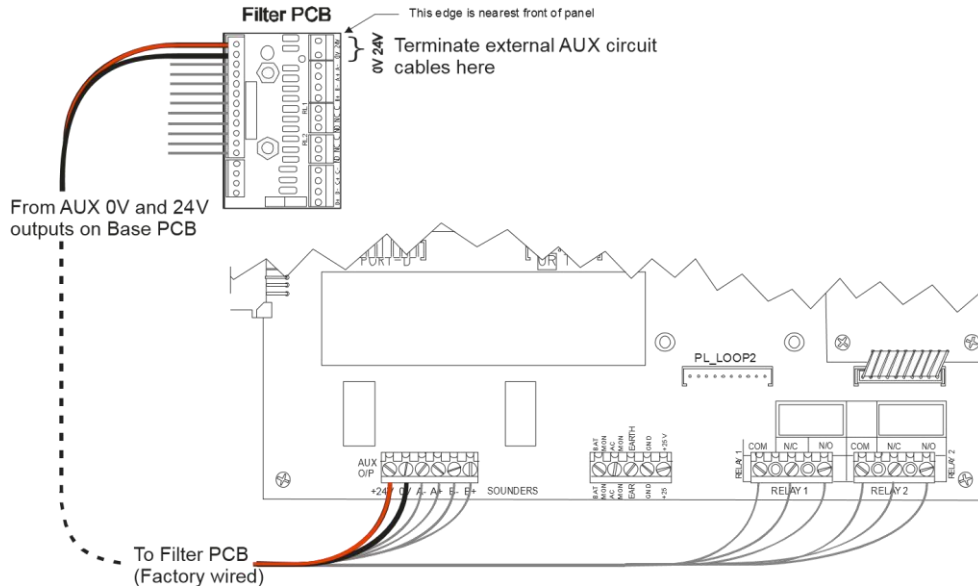

Figure 19 – Auxiliary Output Connections – ZX1Se / ZX2Se

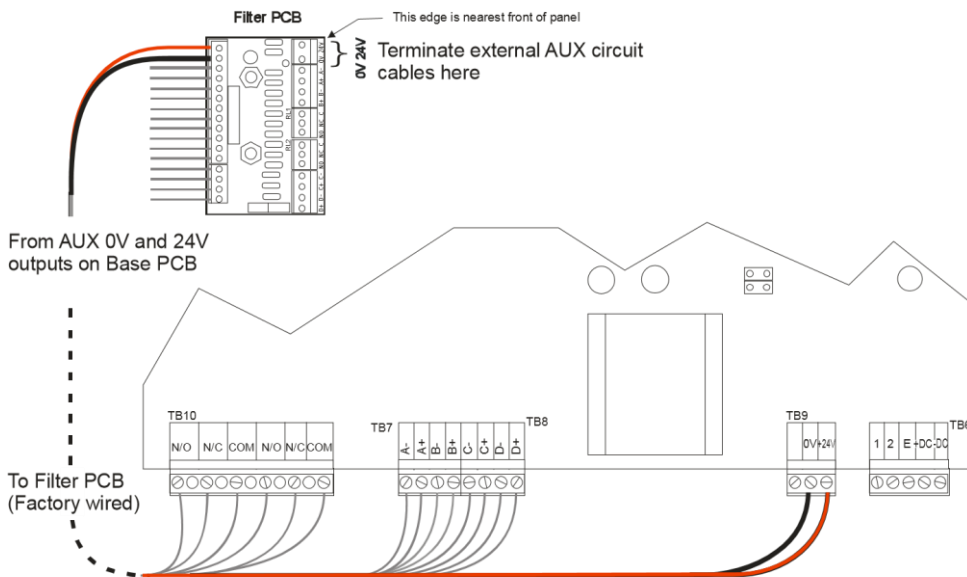

Figure 20 – Auxiliary Output Connections – ZX5Se



The total current loading of all detection loops, sounder circuits and auxiliary supply must not exceed the rated output capability of the panel – refer to specification tables.

3.4.7 Panel Networking / Graphics PC Interface

- The Panel Network (Master to Slave panel) interface uses Port 'C' position on the base card.
- A Master Panel (ZX5Se and ZX10Se only) can also be connected either to a Superior Master or to a Graphics PC using the Port 'B' position on the base card.



EN54-2 12.5

Integrity of transmission paths:

The network does not provide the required transmission path integrity.

3.4.7.1 Local Panel Network

- The ZX1Se, ZX2Se, ZX5Se and ZX10Se Fire Alarm Control Panels can be connected in a network of panels with other panels in the ZX Series FACP range.
- The panels can be connected in two types of configuration: A Shared Zone Network in which panels share common zones and function as one system; a Report and Control Network in which individual panels or subsystems are networked for reporting and control purposes only.
- A panel network requires the installation of an Isolated RS485 Interface card in each panel, using the Port 'C' interface position.
- For detailed information on networking and wiring installation for a panel network, refer to document P/N 996-075.

3.4.7.2 Master Panel to Superior Master Panel

- The network can be further extended, by connecting Network Master Panels to a Superior Master Panel (ZX5Se and ZX10Se only).
- The network master panels are connected via an Isolated RS485 Interface Card in the Port 'B' position to the Superior Master panel containing an Isolated RS485 Interface Card in the Port 'C' position.
- For detailed information on networking and wiring installation for a panel network, refer to document P/N 996-075.

3.4.7.3 Panel to Graphics PC

- A Network Master panel or a Superior Master Panel may be connected to a Graphics PC for additional reporting and control purposes (ZX5Se and ZX10Se only).
- The Graphics PC interface requires the installation of either an Isolated RS232 interface or an Isolated RS485 interface card using the Port 'B' position.
- The ZX1Se and ZX2Se panel may be connected to a Graphics PC but may then not be connected in a network of panels.
- For detailed information on connecting and using a Graphics PC, refer to documents P/N 996046 and 996-047.

3.4.8 Peripheral Loop



EN54-2 12.5

Integrity of transmission paths:

The network does not provide the required transmission path integrity.

- The ZX1Se, ZX2Se, ZX5Se and ZX10Se Fire Alarm Control Panels can be connected to a range of serial interface devices via the peripheral loop.
- The peripheral loop interface uses the Port D position on the base card.
- A peripheral loop requires the installation of an Isolated RS485 Interface card in the panel.
- The RS485 peripheral communications link should be installed in a 'daisy chain' or 'loop' type wiring arrangement. For further details, refer to the Installation Guide supplied with the RS485 Interface Card. Refer to document 996-067.
- Each supervised peripheral device must be given an address. The address can be in the range 1 – 126. Refer to the Installation Guide for each peripheral type for details on the allowed address range.
- The maximum number of physical devices that can be connected to the peripheral loop is 31.

Part Number	Device Description	Supervised
709-601-001	ZXr-A Active Remote Annunciator (Repeater)	YES

MORLEY-IAS ZX Fire Alarm Control Panels

709-701-001	ZXr-P Passive Remote Annunciator (Repeater). Not supervised if set to address 0.	Optional
709-001	ZXR5B Active Remote Annunciator (Repeater)	YES
709-101	ZXR4B Passive Remote Annunciator (Repeater)	NO
795-015	EXP-015 4-Way Sounder Module	YES
795-065	EXP-065 40-Way Remote Mimic (LED Driver)	YES
795-014	EXP-014 4-Way Relay Module	YES
795-029	EXP-029 8-Way Input Module	YES
795-057	MODBUS interface unit	YES

Table 4 – List of Compatible Peripheral Devices

3.4.9 RS485 Wiring Arrangements



EN54-2 12.5

Integrity of transmission paths:

The network does not provide the required transmission path integrity.

- The following diagrams show the wiring arrangements for 'daisy chain' and 'loop' installations of the panel network and peripheral data bus interfaces.
- Refer to Section 3.4.13 for a list of recommended cables.

3.4.9.1 Daisy Chain Style Installation

- Form the peripheral or panel RS485 link by taking wires from the A and B terminals at one side of the interface board connector to the A and B terminals of the next device on the link.
- Continue wiring to all the units to be connected to the link – connecting A to A and B to B.
- Install EOL (150R, 0.5W minimum, P/N 170-073151) resistors in the spare terminals in both the

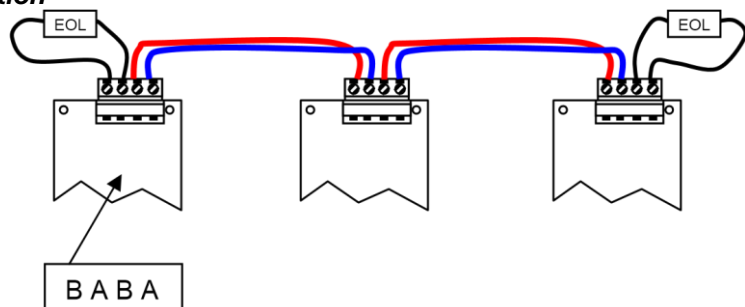

first and last units on the link.

- The maximum allowed length of the link is 1.2km (4000').

Figure 21 – Typical RS485 – 'Daisy Chain' Wiring

wires from the A and B terminals at one side of the interface board connector to the A and B

3.4.9.2 Loop Style Installation

- Form the peripheral or panel RS485 link by taking

ZX Fire Alarm Control Panels MORLEY-IAS

terminals of the next device on the link.

- Continue wiring to all the units to be connected to the link – connecting A to A and B to B.
- Install return wiring from the spare terminals on the last unit to the spare terminals on the first unit.
- The maximum allowed length of the complete loop is 1.2km (4000’).

the cable screens at the nearest earth stud on the Interface board around the Peripheral (or Panel) Link cables.



Using crimp rings terminate the back box. In order to keep the earth tails as short as possible, use an M5 nut to space the tail crimp rings from the back box and to achieve adequate earth bonding.

The figure opposite shows the typical arrangement for a typical installation.

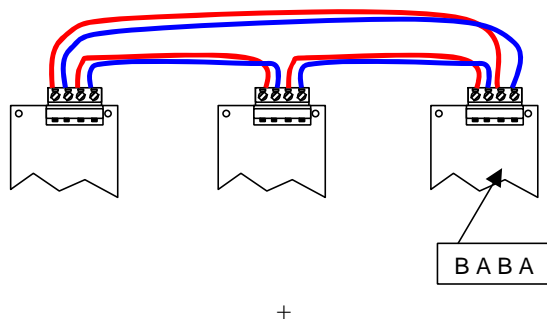

wall of back box - keep length as short as possible

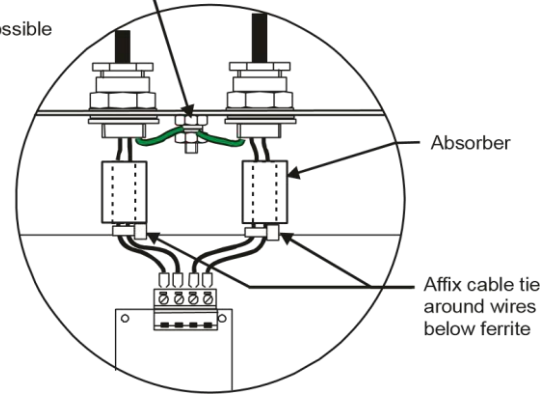

Connect Earth drain wire of cables to nearest earth stud on inner, top

3.4.9.3 EMC Compliance

For EMC Compliance, fit **Figure 22** – Typical RS485 – ‘Loop’ Wiring the Ferrite Absorber supplied with the RS485



3.4.9.4 Cable Screen – Earth Connections

- During installation of a panel network the consequences of connecting remote grounds together must be considered.
- When wiring between RS485 cards and/or peripherals if a drain earth wire is available it **should not** be bonded to the chassis at both ends of the link.

Figure 23 – RS485 Loop – EMC Absorber Installation

MORLEY-IAS ZX Fire Alarm Control Panels

- The drain earth wire should only be bonded to one of the panel back boxes at the cable gland or provided earth studs. The other end should not be bonded directly to the back box but should be connected through a nonpolarised 2.2µF capacitor.

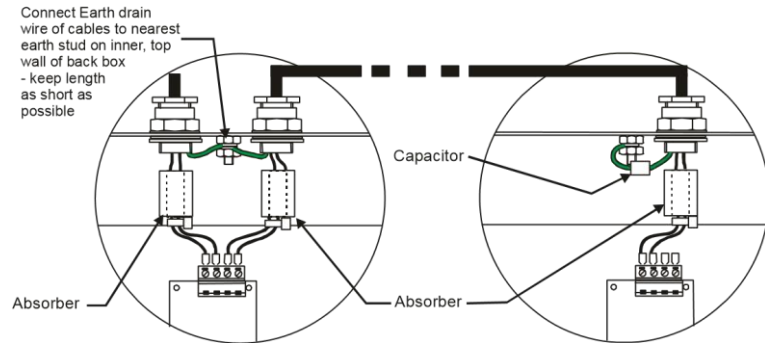

- This arrangement is **Figure 24 – RS485 Screen – Earth Arrangement** shown opposite.

3.4.10 High Integrity Loop

- Hi485 Interface Modules can be used to create a 'High Integrity' RS485 Communications Loop for use on the Panel Network and Peripheral interface links.
- The 'High Integrity' Loop provides open and short circuit protection to ensure that information can still be passed around the loop if a single fault occurs. The loop can be extended to provide a communications network of up to 12km (39000') in distance.
- Refer to the Hi485 Installation Guide (996-065) for further information.

3.4.11 Group Disable Input

- The panel can be configured for an input device (loop call point / switch monitor or peripheral input) to act as a group-disable function. Refer to the Commissioning Manual for programming information.



- The operation of a 'Group Disable' input **MUST** be restricted to Level 2 access only. Install accordingly using a key switch to activate.

3.4.12 Class Change Input

- A call point / switch monitor unit or peripheral input can be configured to activate as a class change input (refer to the Commissioning Manual for programming information).

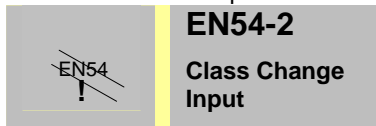

- The operation of a 'Class Change' input **MUST** be restricted to Level 2 access only. Install accordingly using a key switch to activate or locate in a restricted area.

3.4.13 Recommended Cables



All cables connected to the ZX1Se, ZX2Se, ZX5Se or ZX10Se Fire Alarm Control Panels should be of an approved fire-resistant type. The drain earth wire, where available, should be connected to the earth tag on the cable entry gland and to a suitable earth point at the remote end of the cable.



Only use appropriate fire-rated cables for signalling loops and sounder circuits as mandated in relevant local standards and approved by the AHJ. For further details on recommended fire-rated cables refer to Section 6.3 Recommended Cables.



It is recommended that the system is wired using 2-core cables and each 2-core cable should be specific to one function. **DO NOT** use 4-core cables.

ZX Fire Alarm Control Panels MORLEY-IAS

3.4.14 Cable Routing

- Cables should be routed within the enclosure in accordance with the following diagram. Ensure that power-limited cables are routed separately from AC Mains and non-power-limited cables.

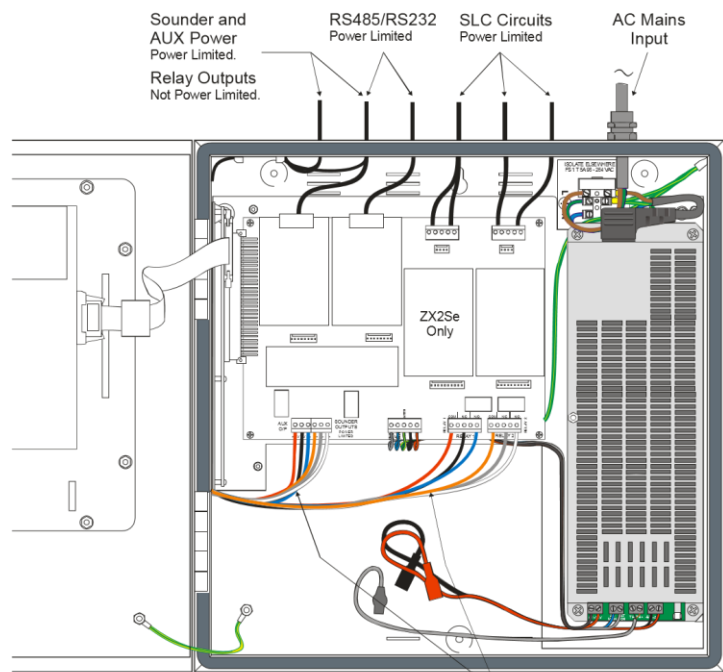

Figure 25 – Recommended Cable Routing Arrangement – ZX1Se / ZX2Se

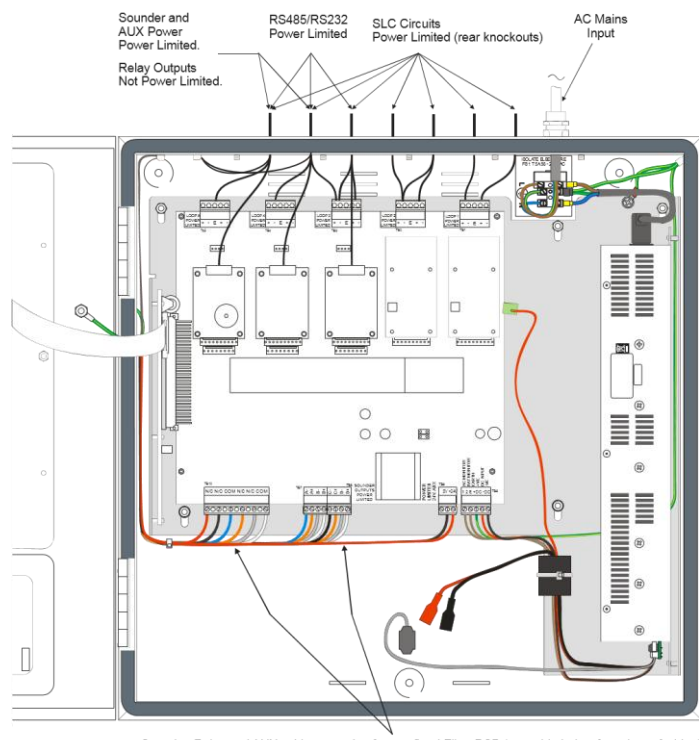

Figure 26 – Recommended Cable Routing Arrangement – ZX5Se

MORLEY-IAS ZX Fire Alarm Control Panels

3.5 Installing Additional Equipment

3.5.1 General Introduction



Always ensure that the mains and battery power supplies have been isolated before plugging or unplugging any of the internal circuit boards.



Follow the specific instructions supplied with each item of additional equipment.

At least one loop driver board **MUST** be installed for the unit to operate as a Fire Alarm Control Panel.

- The following diagrams show the locations for installing additional equipment onto the base card.

3.5.1.1 ZX1Se Arrangement

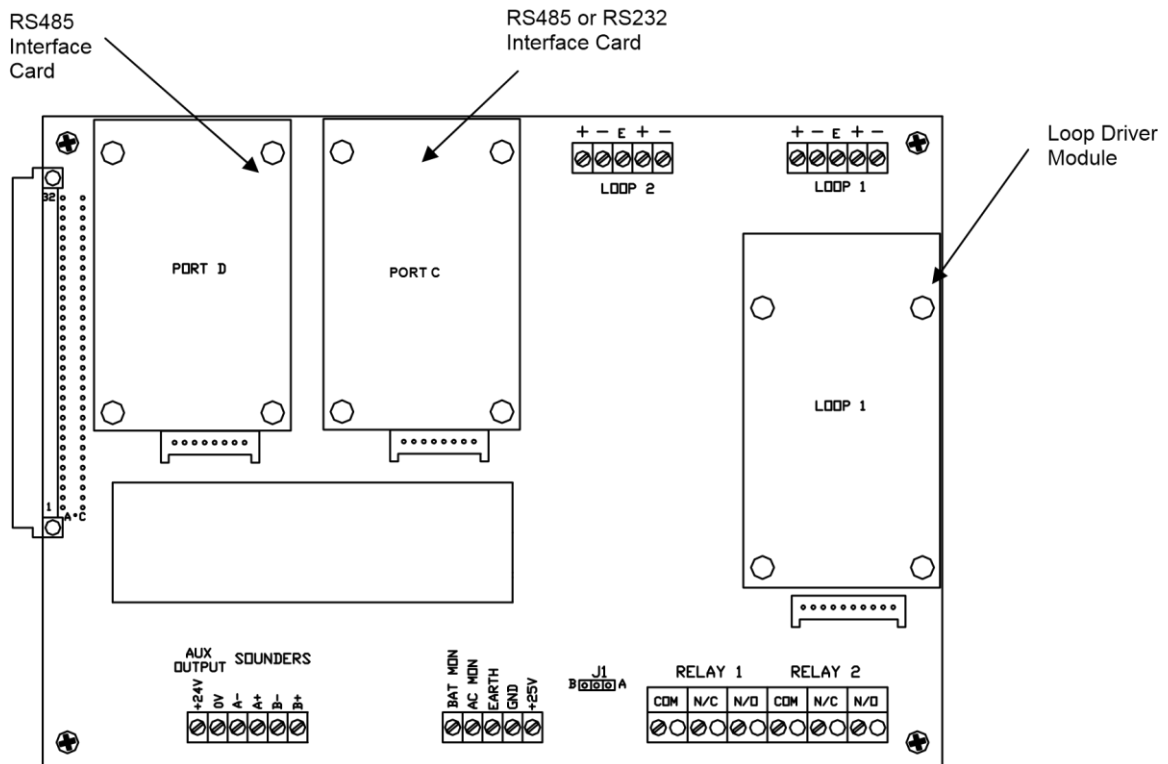

Figure 27 – Positions for Additional Boards – ZX1Se

ZX Fire Alarm Control Panels MORLEY-IAS

3.5.1.2 ZX2Se Arrangement

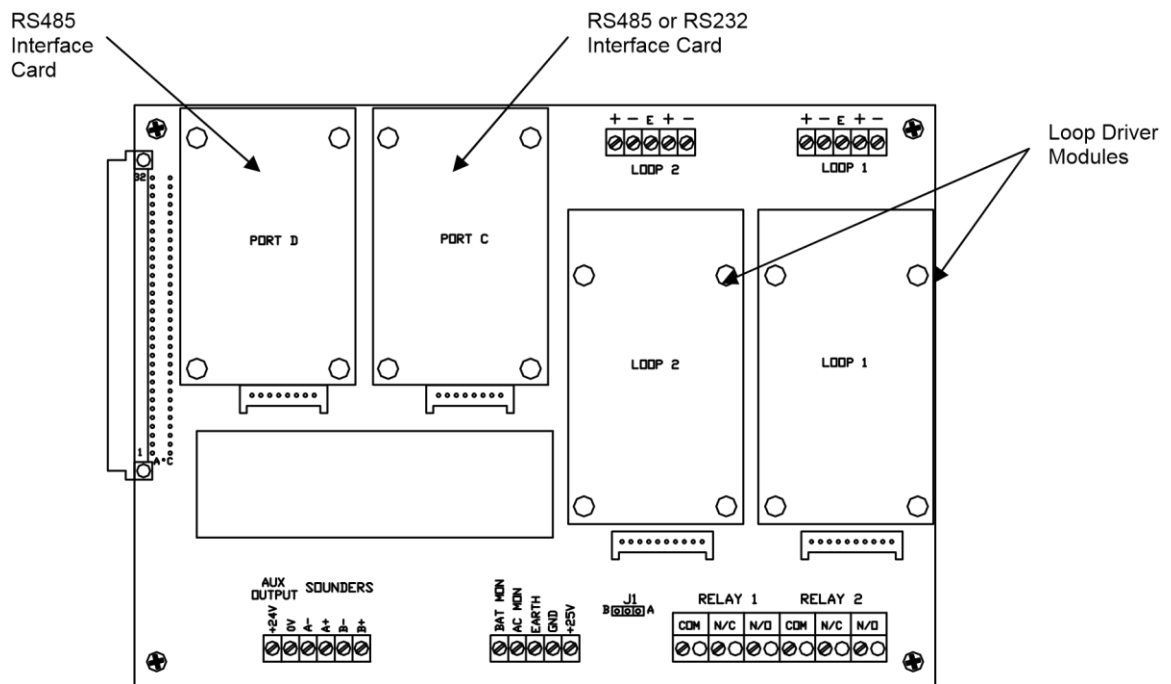

Figure 28 – Positions for Additional Boards – ZX2Se 3.5.1.3

ZX5Se Arrangement

MORLEY-IAS ZX Fire Alarm Control Panels

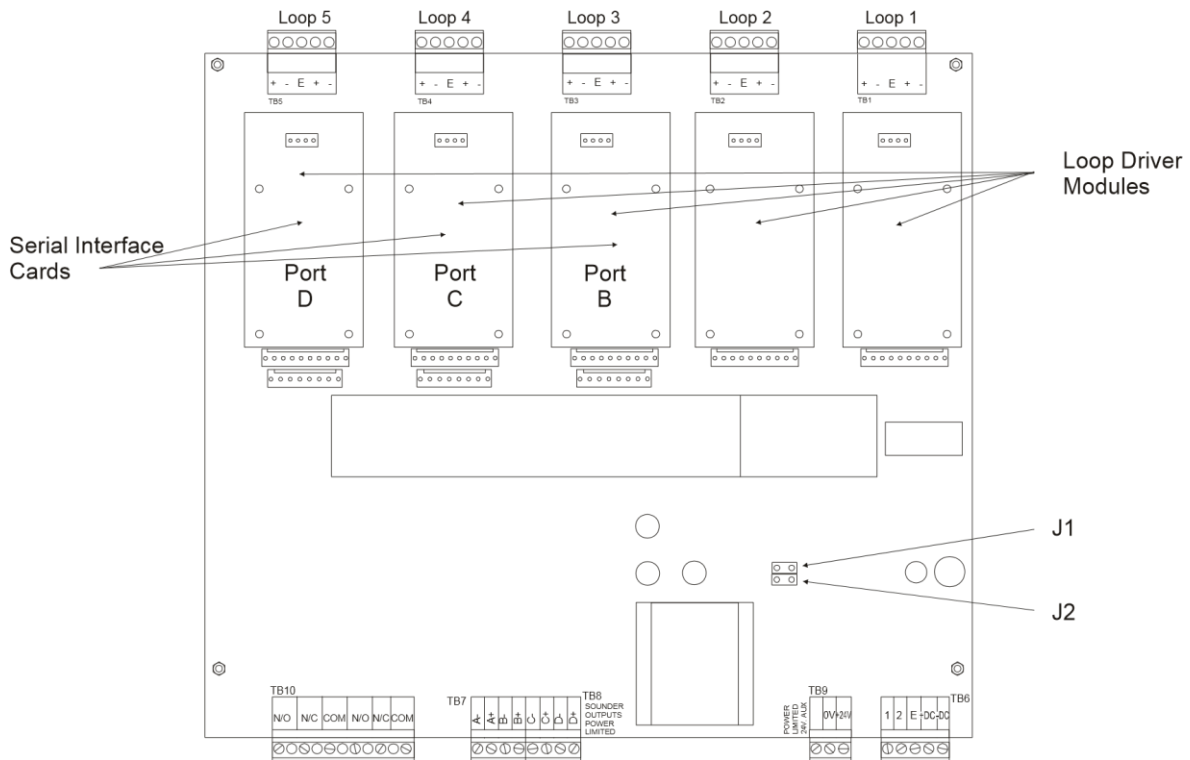

Figure 29 – Positions for Additional Boards – ZX5Se

3.5.2 Loop Driver Cards

- Adding loop driver cards to the base unit expands the system. There are expansion slots for one loop driver card in the ZX1Se, up to two loop driver cards in ZX2Se (designated Loop 1 and Loop 2) and up to five loop drivers in ZX5Se (designated Loop 1 to Loop 5). The ZX10Se can be fitted with up to ten loop drivers – up to five per ZX5Se panel.
- Note that the first loop, designated 'loop 1' is situated at the top right-hand side of the base card.
- Each card is secured with the four M3x6 screws supplied.



When removing a loop driver, the latch on the 4-way header must be pushed away from the connector before attempting to pull the connector out.

Check that both the 10-way and 4-way connectors are correctly aligned and pushed fully home onto the pin headers.

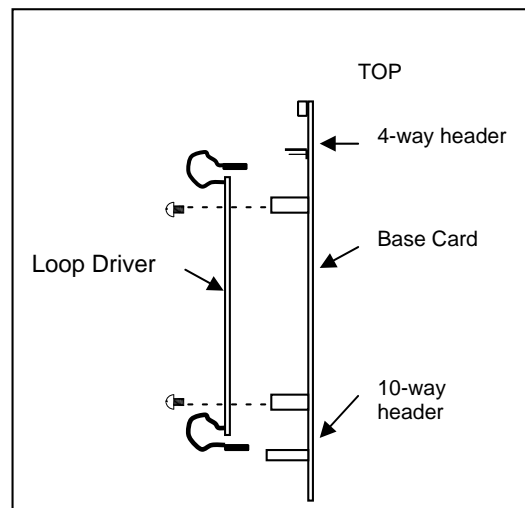

Figure 30 – Mounting the Loop Driver

**The ZX2Se and ZX5Se Fire Alarm Control Panels only supports one manufacturer loop type at a time.
DO NOT install loop drivers of different types in the panel.**

Refer to the manual supplied with all loop driver variants

ZX Fire Alarm Control Panels MORLEY-IAS

3.5.2.1 Voltage Selection

- The installation of each loop driver card requires the setting of a link, or links, to adjust the loop driver power supply for compliance with the different manufacturers' protocols.

3.5.2.1.1 ZX1Se / ZX2Se Jumper Settings

- The loop voltage for each loop driver type is selected using the jumper link J1. The following table defines the position of J1 for each loop driver.

Loop Driver	J1 Position
Morley-IAS (Part 795-072-100)	A
System Sensor (Part 795-068-100)	A
Apollo (Part 795-066 or 795-066-100)	A
Hochiki (Part 795-058-005 or 795-058-105)	A
Nittan (Part 795-044-001)	B

Table 5 – Jumper Setting for Loop Voltage



Ensure that the Jumper setting is in the correct position for the installed loop driver module before applying any power to the panel.

3.5.2.1.2 ZX5Se Jumper Settings

- The loop voltage for each loop driver type is selected using the jumper links J1 and J2. The following table defines the jumper position for each loop driver.

Loop Driver	J1 Position	J2 Position
Morley-IAS (Part 795-072-100) *	Fitted	-
System Sensor (Part 795-068-100) *	Fitted	-
Apollo (Part 795-066 or 795-066-100)	Fitted	-
Hochiki (795-058-005 or 795-058-105)	Fitted	-
Nittan (795-044-001)	-	Fitted

Table 6 – Jumper Setting for Loop Voltage

- Setting the loop voltage for loop driver types for the ZX10Se FACP is the same as for the ZX5Se.



Ensure that the Jumper setting is in the correct position for the installed loop driver module before applying any power to the panel.

3.5.3 485 / 232 Interface Cards

- The system can be expanded to provide a data interface between the panel and control centres, peripheral devices, repeaters and annunciators and to network with other panels.

MORLEY-IAS ZX Fire Alarm Control Panels

- The ZX1Se/ZX2Se base card is provided with two serial ports (labelled C and D) to which isolated RS485 and RS232 serial interface cards can be fitted.



EN54-2 12.5

Integrity of transmission paths:

Use of these interface cards will not give the required transmission path integrity.

- The ZX5Se base card is provided with three serial ports B, C and D (labelled PL2, PL3 and PL4) to which isolated RS485 and RS232 serial interface cards can be fitted.

- Port D supports up to 31 peripheral devices on an RS485 communications bus. These devices can be active ZXR5B or passive ZXR4B remote annunciators (repeaters), 4-way sounder modules, 4-way relay modules, 8-way input modules, 40-way Event Mimic (LED driver) modules and Hi485 modules.

- Port C supports a panel network connection using an RS485 communications bus or a panel to graphic PC data link using either an RS232 or an RS485 communications link.

- Port B (ZX5Se and ZX10Se only) supports a network connection to a superior master panel using an RS485 communications bus or a panel to graphic PC data link using either an RS232 or an RS485 communications link.

3.5.3.1 Mounting the Card Directly to the Base Card

- Use either the four fixing screws (M3 x 6mm) or the four nylon spacers (M3 x 30mm), supplied with the module, to mount the card onto the nylon spacers on the base card.
- Plug the 8-way ribbon cable connector into the 8-way socket (S-PORT-C and SPORT-D on ZX1Se/ZX2Se, PL2, PL3, PL4 on ZX5Se) on the base card. Ensure the connector is fully inserted and that there is no misalignment.



Ensure that the 8-way ribbon cable connector IS NOT inserted into the 10-way connector on the ZX5Se base card.

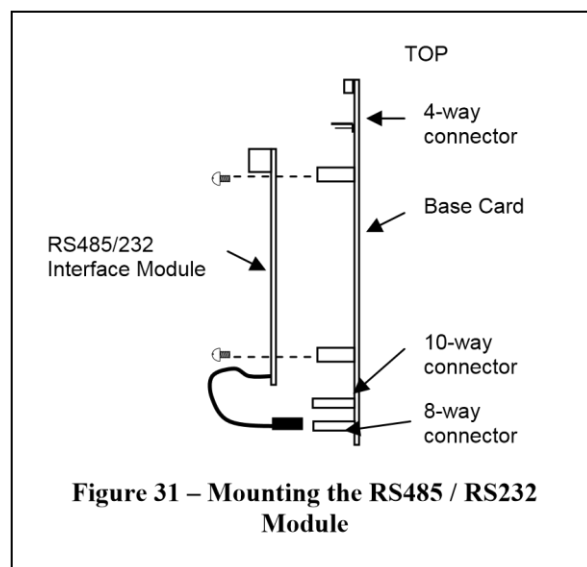

Figure 31 – Mounting the RS485 / RS232 Module

3.5.3.2 Mounting the Card Above the Loop Driver Module

- The three serial interfaces may require to be installed on top of the loop driver boards (loops 3 – 5) in the ZX5Se or ZX10Se panel.
- Use the four nylon spacers (M3 x 30mm), supplied with the RS485 module, to mount the loop driver card to the base card.
- Use the four fixing screws (M3 x 6mm), supplied with the module, to mount the RS485 card onto the nylon spacers on the loop driver card.
- Plug the 10-way and 4-way ribbon cable connectors of the loop driver card into the appropriate sockets on the base card.

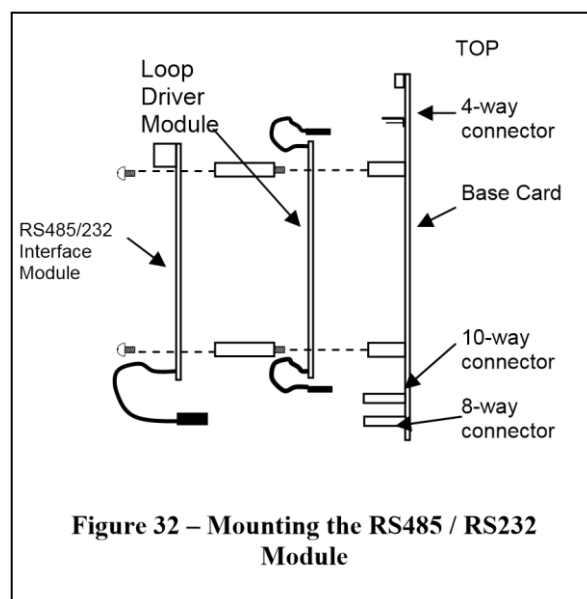

Figure 32 – Mounting the RS485 / RS232 Module

ZX Fire Alarm Control Panels MORLEY-IAS

- Plug the 8-way ribbon cable connector from the interface card into the 8-way socket (PL2, PL3, or PL4) on the base card. Ensure the connector is fully inserted and that there is no misalignment.

3.5.4 Printer Module (ZX5Se / ZX10Se Only)

- The printer module is mounted to the reverse of the front panel door on the printer mounting plate.
- Working from the rear of the panel mounting plate, carefully cut a slot in the front panel label using the slot in the metal plate as a guide. Remove any sharp edges around the periphery of the slot. Affix the self-adhesive tear-off guide, centrally over the slot, to the front of the panel.
- Screw down two of the supplied M3 nuts on to the metal studs on the printer mounting plate to act as spacers.
- Mount the printer assembly to the metal studs and secure in position with the remaining two M3 nuts, spring and plain washers. Ensure that the paper feeds through the slot.
- Connect the supplied 4-way ribbon cable between the printer driver board and the connector on the CPU Board. Fasten down the cable along the inner lid using tie-wraps and adhesive bases.
- Connect the supplied cable at one end to the 0V and +12V connections on the PSU and the other end to the 2-way connector on the printer driver board - polarity is not important. Fasten the leads to the chassis using cable ties and adhesive bases.
- After re-applying power, press the 'FEED' button on the printer assembly and ensure that the printer correctly feeds paper and the paper does not jam in the exit slot.

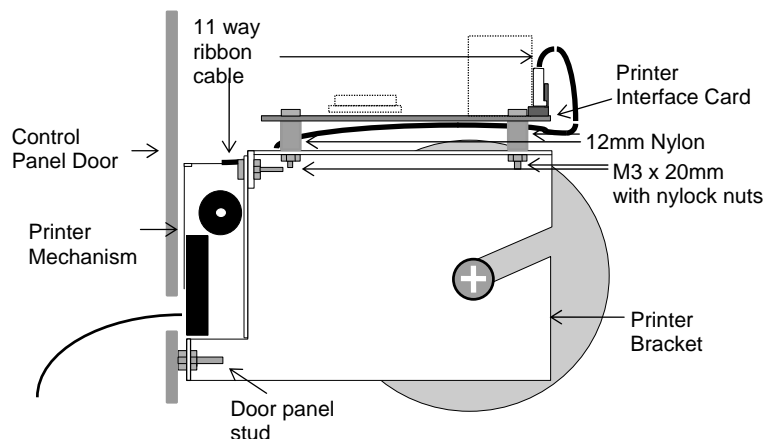

3.5.5 Keyswitch Option (ZX5Se / ZX10Se Only)

- The Keyswitch option is mounted on the upper fascia plate adjacent to the LCD display through a 'double D' cutout behind the front panel label.
- Working from the rear of the panel mounting plate, carefully cut a hole in the front panel label using the double D hole in the metal plate as a guide.
- Thread the cable and switch barrel through the hole from the front and fasten in place with the barrel nut supplied.
- Connect the cable to the 3-way socket on the display card (circled below).

MORLEY-IAS ZX Fire Alarm Control Panels

- Refer to the Commissioning Manual to configure the keyswitch to enable/disable the control keys.

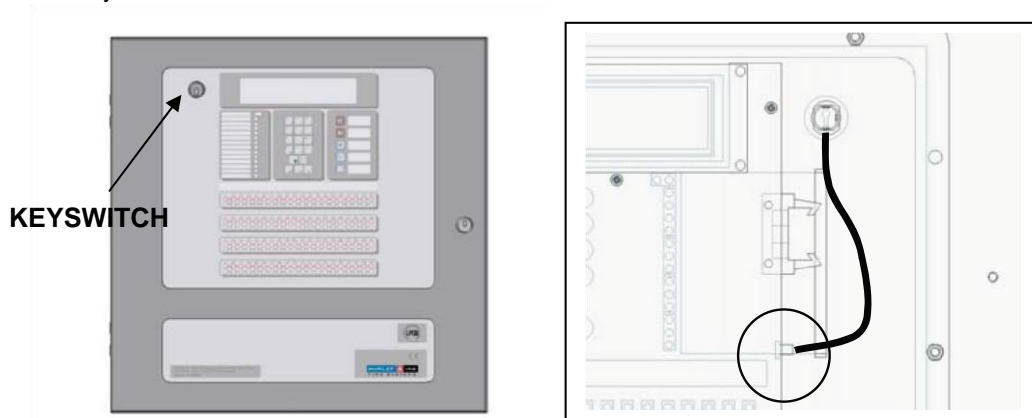

Note: Only the ZX5Se panel is shown here.

4 Standby Battery Calculations

Item	Qty	Quiescent Condition A		Alarm Condition B	
		Each Unit	Total (A) (Units x Qty)	Each Unit	Total (A) (Units x Qty)
ZX1Se/ ZX2Se Panel	1	0.090	0.090	0.310	0.310
RS485 Module (EXP-004)		0.059		0.059	
RS485 Module (EXP-004B)		0.025		0.025	
RS232 Module (EXP-005)		0.059		0.059	
<i>Loop Driver Modules</i>					
Morley-IAS (795-072-100)		0.012		0.12	
System Sensor (795-068-100)		0.012		0.012	
Apollo (795-066-100)		0.012		0.012	
Hochiki (795-058-105)		0.021		0.021	
Nittan (795-044-001)		0.035		0.035	
<i>Peripheral Units</i>		<i>(Maximum 0.340 Amps total auxiliary 24V DC supply)⁴</i>		<i>(Maximum 0.340 Amps total auxiliary 24V DC supply)⁴</i>	
ZXR5B (Active)		0.125 ²		0.159 ³	
ZXR4B (Passive)		0.125 ²		0.150 ³	
4-Way Relay (EXP-014)		0.080 ²		0.160 ³	
8-Way Input (EXP-029)		0.065 ²		0.097 ²	
4-way sounder (EXP-015)		0.120 ²		3.220 ³	
40-way Event / Mimic LED (EXP-065)		0.030 ²		0.277 ³	
Hi485 (EXP-038) or (EXP-038B)		0.040 ²		0.100 ²	
<i>Sensor Current¹</i>					
Sounder A Load					
Sounder B Load					

Other devices connected to the system but not listed above.

		Total A		Total B	
		Standby Period	Total A x 24 =	Alarm Period	Total B x 0.5 =
		Total C		Total D	
		Battery Ah (C + D) x 1.25 =			

Table 7 – Current Rating Chart – ZX1Se / ZX2Se

1: Refer to Section –4.1 below.

2: Typical Quiescent currents quoted. Refer to data sheet for supply current range in all conditions.

3: Maximum Alarm Load quoted. Refer to data sheet for supply current range in all conditions.

4: Ensure total load of peripherals under all alarm and operating or fault conditions does not exceed maximum rating quoted. 1: Refer to Section – 4.1 below.

ZX Fire Alarm Control Panels MORLEY-IAS

- Use the current rating chart, along with the following formulae, to determine the size of the batteries to satisfy the specific installation conditions.
- Batteries with capacity greater than 24Ah should be installed in a separate enclosure that is suitable for Fire Protection Use such as Battery Box – 797-078, with wiring connected to the panel through conduit.

4.1 Sensor Current Calculations

4.1.1 Quiescent Load

- Refer to the manufacturers' published data sheets for the supply current required by each sensor type in normal mode. Take into account the figures quoted for whether the detector LED flashes when the signalling device is addressed – refer to the Commissioning manual for details of the Setup parameter to turn this blinking on / off.
- Calculate the total current required by the sensors connected to all signalling loops. This should be based on the quantity of each device installed and the supply current required for the device.

4.1.2 Alarm Load

- Refer to the manufacturer's published data sheets for the supply current required by each sensor type.
- Calculate the total current required by the sensors connected to all signalling loops. This should be based on the quantity of each device installed and the supply current required for the device as above.
- When a fire alarm condition is registered, the panel will turn on the sensor LED indicators for the first four sensors that register an alarm. Refer to the manufacturers' data sheet for the current supply required for these LED indicators.
- Calculate the total current required by any loop-driven sounders or output modules active in alarm conditions. NOTE: The LED of all activated System Sensor output modules will be turned ON.

4.1.3 Adjustment Factors

- The figures calculated for sensor current, above, should be multiplied by an adjustment factor of 1.8 before being used in the Current Rating Chart.

4.2 Local Systems Ampere Hour Calculation

- Use the following formula to calculate the size of batteries required for the installation. $C = \text{Total A} * 24 \text{ hours}$
- These installations require a standby period of $D = \text{Total B} * 0.5 \text{ hours}$ 24 hours plus thirty minutes of alarm operation at the end of the standby period. **Battery Ah = 1.25 * (C + D)**

5 Maintenance

5.1 Maintenance Schedule

- The following Maintenance routine as recommended in EN54-14 should be adopted.

5.1.1 Daily Attention

- The user should check the following:

MORLEY-IAS ZX Fire Alarm Control Panels

1. The panel should indicate normal operation and if not the fault should be recorded in a logbook and reported to the servicing organization.
2. Any faults previously reported have received attention.

5.1.2 Monthly Attention

- The user should check the following:
 1. Any stand-by generators should be started and fuel levels checked.
 2. At least one call point or detector (from different zones each month) should be operated to test the fire panel and any connected alarm/ warning devices.
 3. Where permissible, any link to the fire brigade or remote manned centre should be operated.
- Any faults should be recorded in the log book and corrective action taken as soon as possible.

5.1.3 Quarterly Attention

- The service organization should arrange to test the following:
 1. Check entries in the logbook & inspect the panel's log, taking appropriate remedial action where necessary.
 2. Examine all battery connections.
 3. Check the alarm, fault and ancillary functions of the control and indicating equipment.
 4. Visually inspect the control and indicating equipment for any moisture ingress or other deterioration.
 5. Enquire if any structural alterations have been made which could affect the operation of call points, detectors or sounders, if so carry out a visual inspection.
- Any defects should be recorded in the logbook and corrective action taken as soon as possible.

5.1.4 Yearly Attention

- The service organization should arrange to test the following:
 1. Carry out the test and inspection routines recommended daily, monthly & quarterly.
 2. 'Walk Test' the system and check that each detector operates in accordance with the manufacturer's recommendations.
 3. Visually inspect all cable fittings and ensure equipment is secure, undamaged and adequately protected.
 4. Examine and test all batteries NB: Note the expected operating life shown in Section E.
- Any defects should be recorded in the logbook and corrective action taken as soon as possible.

5.2 Replacement of Components

- All components used in the control panel have been chosen for high reliability and long life. The manufacturers' data on the following items indicates that they may have a life expectancy of less than 15 years and so may need to be replaced in the future.

ZX Fire Alarm Control Panels MORLEY-IAS

5.2.1 Lithium Standby battery

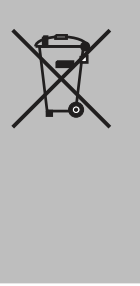

- The CPU card contains a lithium battery; this battery, BAT 1, is a non-user serviceable item. In the unlikely event of the battery failing please contact your service organisation for a replacement CPU card. For end-of-life disposal, the battery must be removed from the CPU card, by using side cutters to cut the mounting pins, and disposed of separately through a suitable battery disposal route. Contact your Local Authority to determine the procedures for the disposal of batteries and waste electrical and electronic equipment.
- The expected battery life is 10 years in normal service. However, this is reduced to 4 years if the CPU card is stored as an un-powered spare part.

5.2.2 Liquid Crystal Alphanumeric Display

Manufacturer's expected life	-	In excess of 10 Years.
Recommended replacement	-	When the display becomes difficult to read.

- The LED backlit liquid crystal display gives a life that is significantly better than most other display technologies. The contrast of the LCD will gradually deteriorate as this part ages. This item should, therefore, be changed when normal contrast starts to fade.

5.2.3 Standby Batteries

Manufacturer's expected life	-	3-5 years at an ambient temperature of 20° Celsius, NB life decreases approximately 50% for every 10° Celsius increase in temperature.
Recommended service	-	Contact Battery manufacturer / supplier
Recommended Suppliers	-	Yuasa
Types	-	12AH Model#: NP12-12
	-	17AH Model#: NP17-12I
	-	24AH Model#: NP24-12I

Before installation.



New Batteries require 'top charging' prior to being put into service.
Yuasa recommend top charging at 28.8V DC for 15 – 20 hours for batteries up to 6 months old from date of manufacture.



It is normal for lead-acid type batteries to discharge hydrogen while being charged. The panel is adequately ventilated to dissipate this hydrogen.

DO NOT seal the panel enclosure or mount the panel in a sealed enclosure or cavity.



Dispose of batteries in a responsible manner and in accordance with any local regulations.

6 Specifications

6.1 Functional Specifications

Specification Item	Values
--------------------	--------

MORLEY-IAS ZX Fire Alarm Control Panels

Enclosure	400mm wide, 400mm high, 135 mm deep Sealed to IP30.
Weight	10 kg without batteries. 18.5 kg with 12Ah batteries fitted.
Operating Temperature	0°C to +40°C
Relative Humidity	85% (non-condensing)
Knockouts (20mm)	14 (Top), 2 (Bottom)
Sounder (NAC) Output	2 programmable outputs. Open- and short-circuit monitored. 6k8, EOL resistors (P/N 170-073-682). 1A maximum output current. Minimum switched current – 1mA
Auxiliary Relay	2 volt-free, changeover outputs. Relay 1 configured as Fault output. Relay 2 configured as Fire output. Contacts rated at 30V AC/DC @ 1 Amp maximum. Minimum switched load – 1mA @ 5V
Sensor Circuit	ZX1Se – 1 plug-in loop driver module per panel. ZX2Se – 1 to 2 plug-in loop driver modules per panel. Supports Analogue Addressable devices over a 2-wire, combined-power and digital-data, transmission loop. Loop Output Voltage and Signalling depends on the loop driver installed – refer to documentation supplied with the loop driver. Maximum Loop Loading is 460mA (with a ULD card) per loop.
Monitoring zones	Up to 20 zones with individual LED indicators. Maximum 120 zones – up to 200 software zones (no LED indicators).

Table 9 – ZX1Se / ZX2Se Functional Specifications

Specification Item	Values
Enclosure	500mm wide, 500mm high, 183 mm deep. Sealed to IP30.
Weight	19 kg without batteries. 38.8 kg with 24Ah batteries fitted.
Operating Temperature	0°C to +40°C
Relative Humidity	85% (non-condensing)

ZX Fire Alarm Control Panels MORLEY-IAS

Knockouts (20mm)	24 (Top), 24 (Bottom)
Sounder Output	4 programmable outputs. Open- and short-circuit monitored. 6k8, EOL resistors (P/N 170-073-682). 1A maximum output current. Minimum switched current – 1mA.
Auxiliary Relay	2 volt-free, changeover outputs. Relay 1 configured as Fault output. Relay 2 configured as Fire output. Contacts rated at 30V AC/DC @ 1 Amp maximum. Minimum switched load – 1mA @ 5V
Sensor Circuit	1 to 5 plug-in loop driver modules per panel. Supports Analogue Addressable devices over a 2-wire, combined-power and digital-data, transmission loop. Loop Output Voltage and Signalling depends on the loop driver installed – refer to documentation supplied with the loop driver. Maximum Loop Loading is 460mA (with a ULD card) per loop.
Monitoring zones	Up to 20 zones with individual LED indicators, expandable to 40 / 80 zones with optional LED indicator boards. Maximum 120 zones – up to 200 software zones (no LED indicators).

Table 10 – ZX5Se Functional Specifications

6.2 Power Supply and Charger

Specification Item	Values
Input Voltage	115V to 230V AC 47-63Hz
Voltage tolerance	±15%
Incoming mains fuse	F1 T 5A H 250V 20mm (in AC Mains TB)
Power supply fuse	T 5A H 250V 20 mm
Charger Rating	1.75A – temperature-compensated, lead-acid battery charger.
Continuous Power supply Output Rating	2.5 Amps total, comprising: 0.5A Internal circuit boards (2x 485 cards + 2x loop driver cards) 1.3A external load ¹

¹ Depending on the loop protocol, if loop sounders are used the maximum output from each ULD loop driver card will be 470mA. This loop driver and external loop currents must be multiplied by a factor of 1.8 to derive the current draw from the power supply output or standby batteries. This amount will have to be deducted from the 1.3A external load. The Loop & Battery Calculator must be used to verify that there is sufficient current available to drive all the output devices on the loop(s) in alarm.

MORLEY-IAS ZX Fire Alarm Control Panels

D. C. Output Voltage	20 - 26 VDC
Voltage out to Baseboard	20 – 25.5 Vdc
Max. Ripple Voltage	0.2V peak-peak @ maximum output loading.
Battery Charger Output	27.3 V nom. at 20°C (temperature compensated ¹)
Quiescent current	90mA + Loop driver / option card current + external circuits.
Alarm current	310mA + Loop driver / option card current + external circuits.
EN54 Battery Wiring Test impedance	0.45 Ohm
EN54-4 PSU Loadings	$I_{(min)} = 0A$ $I_{max(a)} = 500mA @ 25.0 Vdc$ $I_{max(b)} = 2.3A @ 25.0 Vdc$
Standby Batteries ³	24V sealed, lead acid. Minimum Capacity - 7Ah (Internally Fitted) Maximum Capacity - 12Ah (Internally Fitted)

Table 11 – ZX1Se / ZX2Se Power Supply and Charger Specifications

Specification Item	Values				
Input Voltage	230V AC 47-63 Hz				
Voltage tolerance	±15%				
Incoming mains fuse	FS1 T 5A 250V H 20mm - (in AC Mains TB)				
Power supply fuse	T 5A 250V H 20 mm				
Charger Rating	3A – temperature-compensated, lead-acid battery charger.				
Continuous Power supply Output Rating	140W total available across 2 outputs: <table style="margin-left: 40px;"> <tr> <td>25V Supply (General System)</td> <td>2.25A (55W) max.</td> </tr> <tr> <td>Supply (Loop Driver feed only)²</td> <td>2.50A (85W) max.</td> </tr> </table> <p>0.75 Amps from the 25V supply is reserved for powering Internal circuits. The remainder of available power is for external loads (Conventional sounders, Aux supply & loop current).</p>	25V Supply (General System)	2.25A (55W) max.	Supply (Loop Driver feed only) ²	2.50A (85W) max.
25V Supply (General System)	2.25A (55W) max.				
Supply (Loop Driver feed only) ²	2.50A (85W) max.				
D. C. Output Voltage	26V (un-boosted) Max & 20V Min ² 35V (boosted)				
Voltage out to baseboard	20 – 25.5 Vdc				

¹ Battery charger output is temperature compensated: nominally at 20°C at -36mV/°C ³
Refer to Section 5.2.3 for a list of recommended batteries and suppliers.

² Making use of the 35V output, to supply the loop driver cards directly, avoids the overall restrictions associated with loop supply on the ZX5e. ² Output = Battery voltage – 1.0 volts (down to a battery voltage of 21V) under AC Mains power failure conditions. ³

Battery charger output is temperature compensated nominally at 20°C at -36mV/°C. ⁴
Refer to Section 5.2.3 for a list of recommended batteries and suppliers.

ZX Fire Alarm Control Panels MORLEY-IAS

Voltage out to ULD PCBs	34.2 – 35.5 Vdc
Maximum Ripple Voltage	<0.2V peak-peak on both 25V and 35V outputs.
Battery Charger Output	27.3V nom. at 20°C (temperature compensated ³).
Quiescent current	250mA + loop driver / option card current + external circuits.
Alarm current	490mA + loop driver / option card current + external circuits.
EN54 Battery Wiring Test impedance	0.40 Ohm
EN54-4 PSU Loadings	$I_{(min)} = 0A$ 35.0Vdc: $I_{max(a)} = 0.495A$ $I_{max(b)} = 2.3A$ 25.0Vdc: $I_{max(a)} = 1.0A$ $I_{max(b)} = 2.25A$ 12.0Vdc: $I_{max(a)} = 0.05A$ $I_{max(b)} = 0.16A$
Standby Batteries ⁴	24V sealed, lead acid. Minimum Capacity - 12 Ah Maximum Capacity - 24 Ah
Printer Supply	12VDC for optional panel-mounted printer (2W maximum)

Table 12 - ZX5Se Power Supply and Charger Specifications

6.3 Recommended Cables

- All cables connected to the ZX Series Fire Alarm Control Panels must be fire resistant cables. The drain earth wire, where available, should be connected to the earth tag on the cable entry gland and to a suitable earth point at the remote end of the cable.



In the UK, the British Standard BS5839 Part 1 : 2002 Code of Practice for system design, installation, commissioning and maintenance states the requirements for standard and fire resisting cables in Clause 26.2 section d and e:

'd) Standard fire resisting cables should meet PH30 classification when tested in accordance with EN50200 and maintain circuit integrity if exposed to the following test:

- a sample of the cable is simultaneously exposed to flame at a temperature of 830°C – 0+40°C and mechanical shock for 15 minutes, followed by simultaneous exposure to water spray and mechanical shock for a further 15 minutes.

e) **Enhanced fire resisting cables** should meet the PH120 classification when tested in accordance with EN50200 and maintain circuit integrity if exposed to the following test:

- a sample of the cable is simultaneously exposed to flame at a temperature of 930°C – 0+40°C and mechanical shock for 60 minutes, followed by simultaneous exposure to water spray and mechanical shock for a further 60 minutes.'

Loop cable



A loop cable carries data therefore its selection is important. Note the following:

- In countries where the European EMC directive is in force, only **EMC Compliant** cables are to be used.
- The loop cable usage must not exceed 1.5 km. This includes the cable used on main loop and spur circuits.
- Single pair cables must be used. It is NOT permissible to run mixed loops or outgoing and return pairs in a multi-core cable due to inadequate separation and possible electrical interference problems.
- Each core of the loop cable must be a minimum 1.5mm² cross sectional area.
- The cable screen must be capable of being earthed at each system device – only one end of each cable screen must be earthed.

MORLEY-IAS ZX Fire Alarm Control Panels

- Red is the preferred cover sheath for fire applications
- The specified loop circuit cables are also suitable for wiring alarm, auxiliary relay and input/output lines.



Mains supply cable

The mains supply cable must be a standard fire resisting type and should meet PH30 classification, such as any of the standard and enhanced cables listed below.

- Examples of enhanced and standard cables are:

Enhanced:

- Mineral insulated cable (MICC) to BS6207: Part 1
- Draka FIRETUF Plus Enhanced FTPLUS2EHL5RD Standard:
- Prysmian FP200 FLEX
- Prysmian FP2000 GOLD

- Refer to your supplier for details of other available industry standard fire resisting cables.

- Listed below are fire rated cables for signalling loops and sounder circuits that met the requirements of previous approval standards:

1. AEI type Firetec Multicore Ref. F1C1 (1mm²) to F1C2.5 (2.5mm²) in 2 core.
2. AEI type Firetec Armoured Ref. F2C1 (1.5mm²) to F2C2.5 (2.5mm²) in 2 core.
3. AEI type Mineral Insulated Cable (all types up to 2.5mm²).
4. BICC types Mineral Insulated twin twisted conductor cables, Ref. CCM2T1RG and CCM2T1.5RG.
5. BICC type Mineral Insulated Pyrotenax (all types up to 2.5mm²)
6. CALFLEX type Calflam CWZ 2 core type up to 2.5mm² maximum.
7. Prysmian (formerly PIRELLI) type FP200 Gold 2 core type from 1mm² to 2.5mm²
8. Draka FIRETUF (OHLS) FTZ up to 2.5mm²
 - Signal Cables for RS485 Communications Links (twisted pair)
9. 12 AWG Signal 88202 Belden 9583 WPW999
10. 14 AWG Signal 88402 Belden 9581 WPW995
11. 16 AWG Signal 88602 Belden 9575 WPW991
12. 18 AWG Signal 88802 Belden 9574 WPW975
13. FIRETUF FDZ1000 by Draka 2 core.
14. Prysmian (formerly PIRELLI) type FP200 Gold 2 core.

7 Appendix - ZX10Se Installation

7.1 General

- The ZX10Se FACP has been designed to offer a solution to providing up to ten loops of fire detectors without the need to install the panels in different locations on site. Two ZX5Se FACPs are networked together within one large back box with provision for up to four 17Ah batteries to be fitted. Depending on the configuration, the batteries either can be fitted inside the ZX10Se backbox or, when a large capacity is required, these can be installed in adjacently-located battery boxes (797-077).
- The ZX10Se contains two PSUs and each must be provided with separate, mains supply wiring from separate isolators.

7.2 Warnings and Cautions

- Refer to Section 1.2 Warnings and Cautions before carrying out any procedures described in this manual.

7.3 National Approvals

- Refer to Section 1.3 National Approvals for details of equipment compliance requirements.

7.4 Unpacking

- Refer to 2 Unpacking for details of what equipment should have been supplied with the ZX10Se.

7.5 Installation

- Refer to the procedure described in Section 3.1 Installing the Enclosure and Section 3.1.2 Mounting the Enclosure to the Wall for details of removing the internal equipment prior to installing the ZX10Se enclosure.
- Refer to Section 3.1.3 Remounting the Chassis for details of re-fitting the ZX5Se FACPs in the enclosure.

7.6 Dimensions and Fixing Points

- The ZX10Se FACP has the following physical dimensions and fixing positions:

7.7 Identification of Parts

networked together as shown below:

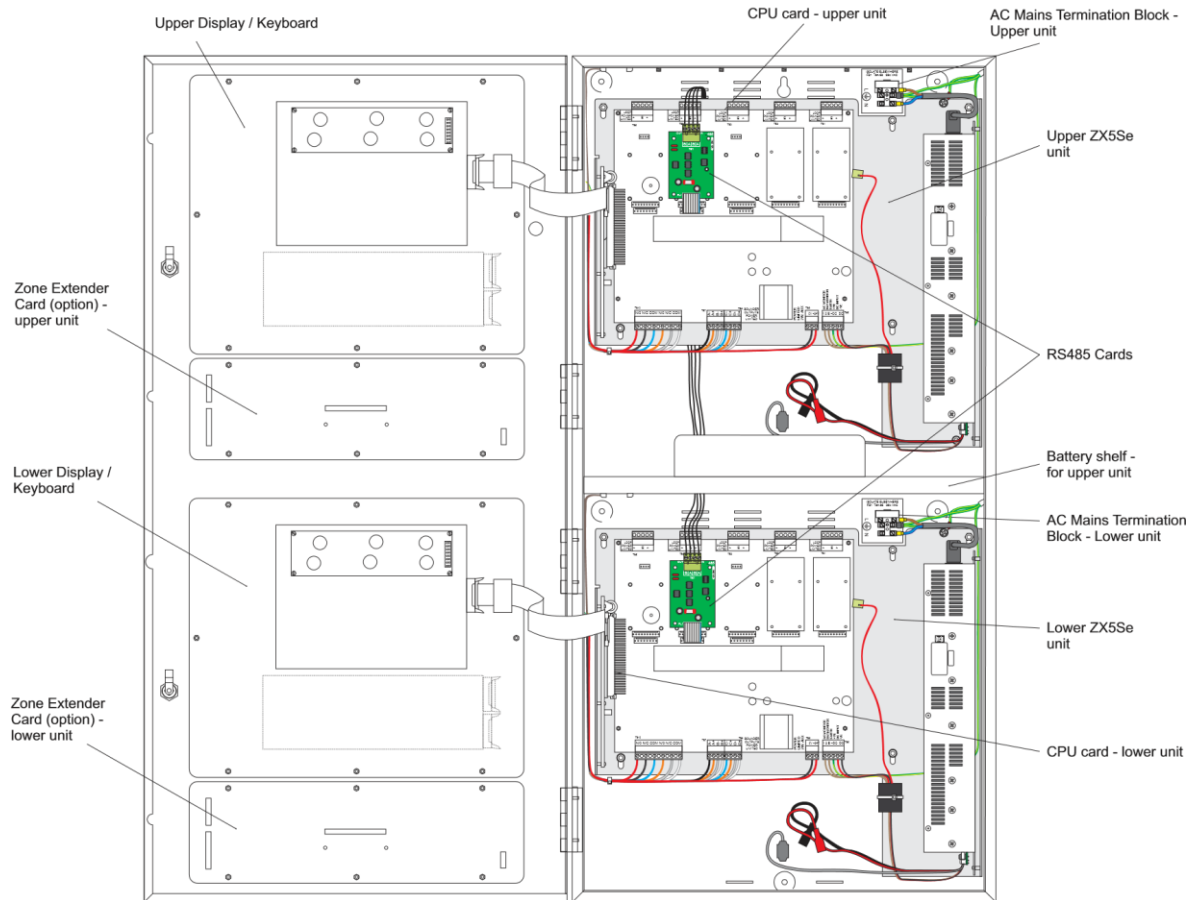

- The ZX10Se comprises two ZX5Se FACP's, installed one above the other in an enclosure and

Figure 34 – Enclosure Arrangement ZX10Se

7.7.1 CPU Card

- Refer to Section 3.3.1 CPU Board for details of the function of the CPU boards.

7.7.2 Display / Keyboard

- Refer to Section 3.3.2 Display / Keyboard for details.

7.7.3 Base Card

- Refer to Section 3.3.3 Base Card for details.

7.7.4 Zone Extender Cards

- The ZX10Se can support up to two 20 Zone or two 60 Zone Extender cards, one fitted to each ZX5Se FACP. For details of part numbers refer to Section 3.3.4 Zone Extender Card or the Zone Expander Guide (P/N 996-137).

MORLEY-IAS ZX Fire Alarm Control Panels

7.7.5 Internal Printer

- The ZX10Se FACP can be augmented by fitting an internal printer in the upper position only on the user interface door. Refer to Section 3.5.4 and to the Commissioning Manual for further information.

7.8 External Connections

BEFORE INSTALLATION: Refer to Ratings / Type label located on one of the ZX5Se panels.

7.8.1 Mains Power Input

- The ZX10Se FACP has the same requirements as the other FACP's in the ZX Series range except that it requires two separate and remotely-isolated power supplies to be brought in and terminated within the enclosure. The mains wiring needs to be terminated at the Mains Termination Blocks (MTBs) provided on each of the ZX5Se FACP's.
 - The drawing at right provides guidance on the routing of the separate mains wiring within the ZX10Se enclosure.
- The incoming power feed cables' or Earth (Green/Yellow) wire should be connected to the terminal block earth connection – middle terminal.



Open and lock out the circuit breaker before connecting any power

Maintain separation between the 115V to 230V supply cable and the low

voltage wiring. Do not route in the same trunking and keep apart in the enclosure.

The panel should be supplied with mains power via a readily-accessible disconnect device (isolation switch) to facilitate servicing and be provided with suitable earth fault protection incorporated in the building installation wiring. The minimum cross-sectional area of the mains cable must be 0.75mm. Each of the two supplies should be protected by a 5A HRC anti-surge fuse.

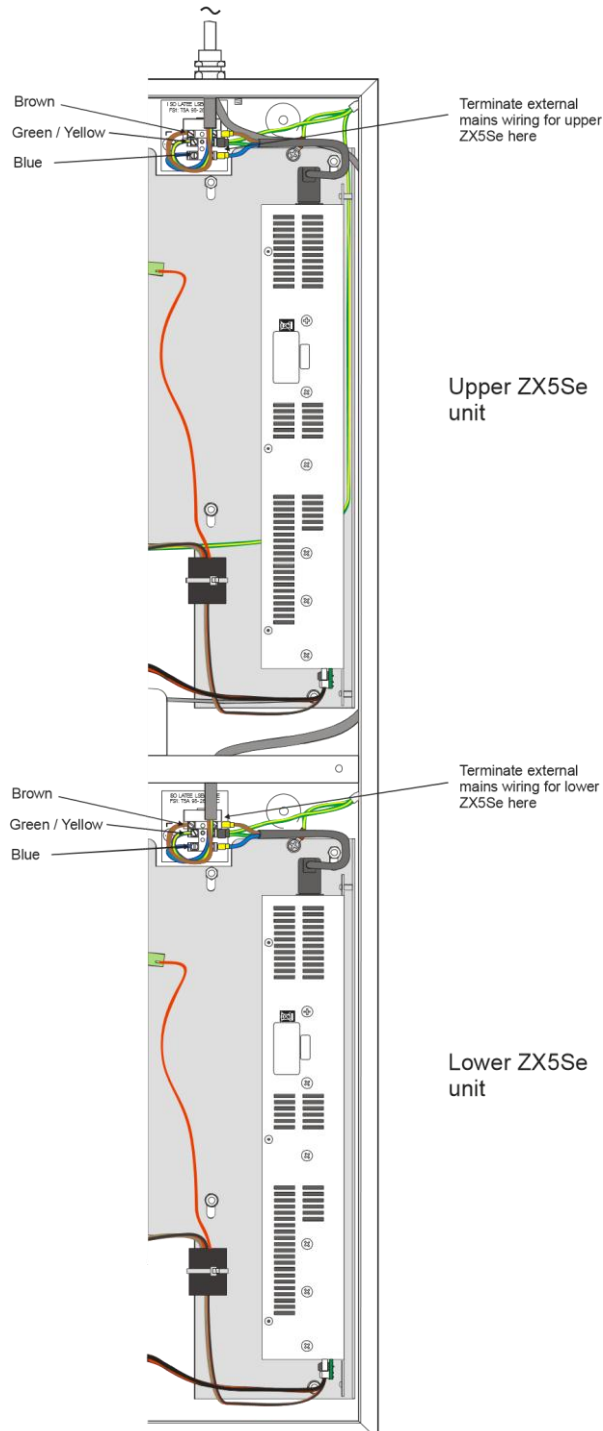

Figure 35 - Mains Input Arrangement – ZX10Se

7.8.2 Mains Cable Glands

- Refer to Section 3.4.1.4 Mains Cable Glands for details of recommended cable glands.

7.9 Battery Installation

- Refer to Section 4 Standby Battery Calculation for calculating the battery backup size requirements for both ZX5Se panels used by the ZX10Se configuration to meet your particular site installation. It is important that you calculate the battery size requirements for **each** ZX5Se panel, especially as the backup requirements may differ between the panels. Refer to Table 8 - Current Rating Chart - ZX5Se.
- The ZX10Se FACP must be backed up with two sets of batteries. If the size of these batteries is calculated to be in excess of 17Ah then they must be installed in two battery boxes suitable for Fire protection use, such as battery box 797-078, located directly adjacent to the side of the ZX10Se enclosure to adequately protect the battery cables. Refer to the diagram below.
- Refer to Section 5.2.3 Standby Batteries for a list of recommended batteries.



Do not make the final battery connection until the installation is complete.

Battery lead connections are not power limited.



Before installation:

New batteries require 'top charging' prior to being put into service.



Figure 36 – ZX10Se Battery Installation – 17Ah or Greater

MORLEY-IAS ZX Fire Alarm Control Panels

7.10 External Wiring Connections

- Refer to the following sections of this manual for information regarding the connection of detection loop cables, sounder circuits and other site installation wiring and cabling:

1. Detection Loops – Section 3.4.3
2. Sounder Circuits - Section 3.4.4
3. Auxiliary Relay Outputs – Section 3.4.5
4. Auxiliary Supply Outputs - Section 3.4.6
5. Panel Networking / Graphics PC Interface – Section 3.4.7
6. Peripheral Loop – Section 3.4.8
7. RS485 Wiring Arrangements – Section 3.4.9
8. High Integrity Loop – Section 3.4.10
9. Recommended Cables – Section 3.4.13

7.11 Cable Routing

- Cables should be routed within the enclosure in accordance with the diagram below.

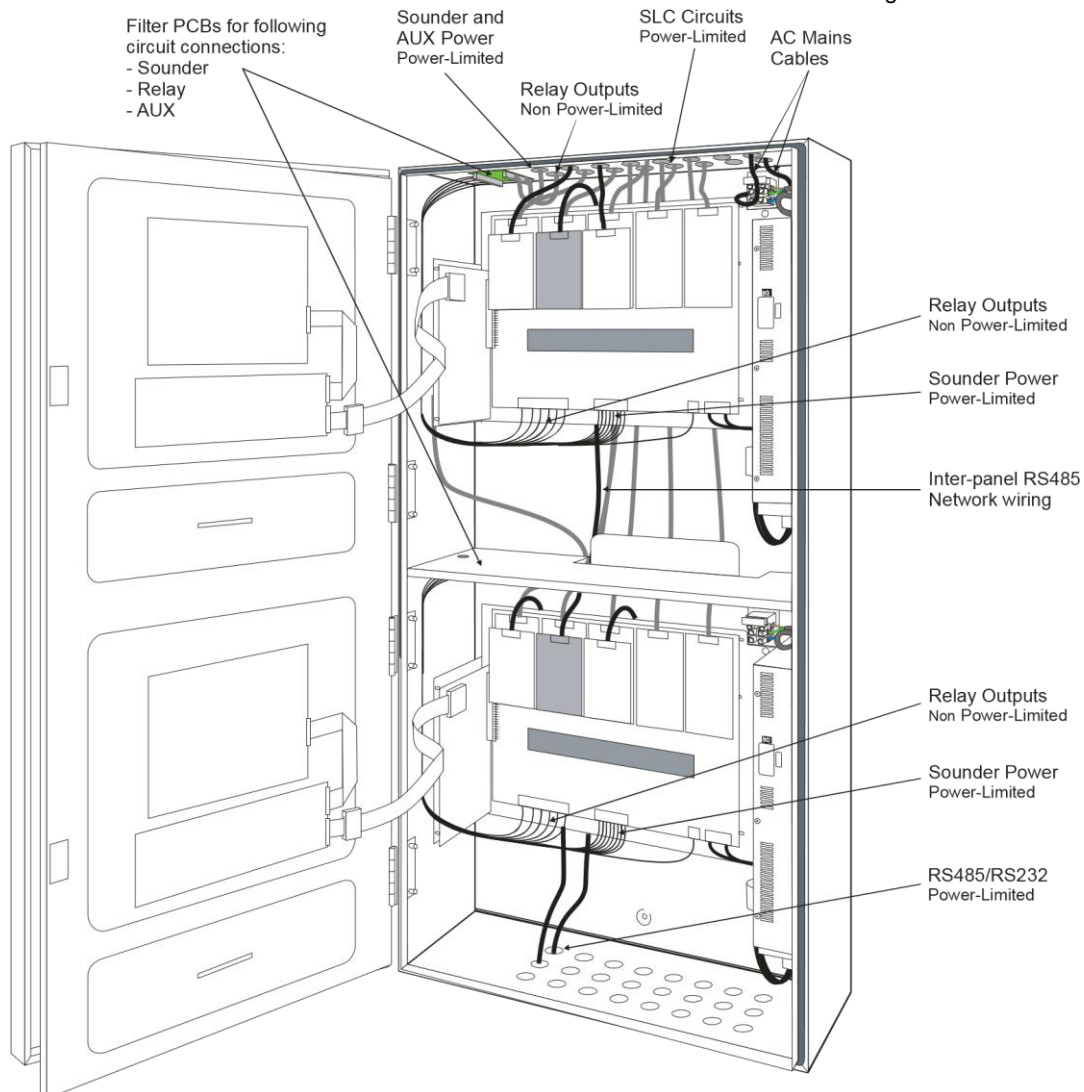

Figure 37 – Recommended Cable Routing Arrangement – ZX10Se

ZX Fire Alarm Control Panels MORLEY-IAS

7.12 Installing Additional Equipment

- Refer to Section 3.5 Installing Additional Equipment for relevant instructions on fitting loop driver cards, RS485 / RS232 interface cards, printer module (top panel only) or key switch option.

7.13 Maintenance

- Refer to Section 5 Maintenance for details relating to all ZX10Se FACP maintenance issues.

7.14 Specification

7.14.1 Functional Specifications

Specification Item	Values
Enclosure	500mm wide, 1000mm high, 185mm deep. Sealed to IP30.
Weight	38kg without batteries. 76.8 kg with 24Ah batteries fitted.
Operating Temperature	0°C to +40°C
Relative Humidity	85% (non-condensing).
Knockouts (20mm)	24 (top), 24 (bottom).
Sounder Output	4 programmable outputs (x2) Open- and short-circuit monitored. 6k8, EOL resistors (P/N 170-073-682). 1A maximum output current. Minimum switched current – 1mA.
Auxiliary Relay	2 volt-free, changeover outputs. Relay 1 configured as Fault output. Relay 2 configured as Fire output. (x2). Contacts rated at 30V AC/DC, 1A maximum.
Sensor Circuit	1 to 5 plug-in loop driver modules per ZX5Se FACP. Supports Analogue Addressable devices over a 2-wire combined power and digital data transmission loop. Loop output voltage and signalling depends on the loop driver installed – refer to documentation supplied with the loop driver. Maximum loop loading is 460mA (with a ULD card).
Monitoring Zones	Up to 20 zones with individual LED indicators, Expandable to 40/80 zones with optional LED indicator boards per (x2). Maximum 120 zones – up to 200 software zones (no LED indicators) – x2.

MORLEY-IAS ZX Fire Alarm Control Panels

Table 13 – ZX10Se Functional Specification

Specification Item	Values
Operating Voltage	115 to 230V AC 47-63Hz.
Voltage tolerance	±15%
Incoming mains fuse (x2)	FS1 T 5A 250V H 20 mm - (in AC Mains TBs)
Power supply fuse	T 5A 250V H 20 mm
Charger Rating (x2)	3A (min) – temperature-compensated, lead-acid battery charger.
Continuous Power supply Output Rating (x 2)	140W total available across 2 outputs: 25V Supply (General System) 2.25A (55W) max. 35V Supply (Loop Driver feed only ¹) 2.50A (85W) max. 0.75 Amps from the 25V supply is reserved for powering Internal circuits. The remainder of available power is for external loads (Conventional sounders, Aux supply & loop current).
DC Output Voltage	26V Max & 20V Min ² . 35V (boosted)
Voltage out to baseboard (x2)	20 – 25.5 Vdc
Voltage out to ULD PCBs (x2)	34.2 – 35.5 Vdc
Maximum Ripple Voltage	<0.2V peak-peak on both 25V and 35V outputs.
Battery Charger Outputs (x2)	27.3 V nom at 20°C (temperature compensated).
Quiescent current	250mA + loop driver / option card current + external circuits.
Alarm current	490mA + loop driver / option card current + external circuits.
EN54 Battery Wiring Test impedance	0.40 Ohm
EN54-4 PSU Loadings	$I_{(min)} = 0A$ 35.0Vdc: $I_{max(a)} = 0.495A$ $I_{max(b)} = 2.3A$ 25.0Vdc: $I_{max(a)} = 1.0A$ $I_{max(b)} = 2.25A$ 12.0Vdc: $I_{max(a)} = 0.05A$ $I_{max(b)} = 0.16A$
Standby Batteries ³	24V sealed, lead acid. Minimum Capacity - 12 Ah (x4). Maximum Capacity - 24 Ah (x4).
Printer Supply	12VDC for optional panel-mounted printer (to be supplied from upper ZX5Se unit only).

Table 14 – ZX10Se Power Supply and Charger Specification

NOTES

¹ Making use of the 35V output, to supply the loop driver cards directly, avoids the overall restrictions associated with loop supply on the ZX10Se. ² Output = Battery voltage – 1.0 volts under mains power failure conditions. ³ Refer to Section 5.2.3 for a list of recommended batteries and suppliers.

